

elektor

up-to-date electronics for lab and leisure

67
November 1980

ISSN 0308-308X

U.K. 60p

U.S.A. \$2

ENERGY SAVERS



m.p.g. meter
improved central heating
draught detector
petrol saver

contents	11-01
selektor	11-01
an r.p.m. indicator as an economy guide	11-04
A car engine is most efficient when the amount of energy it produces is closest to the amount consumed. This occurs at an engine speed that produces the maximum torque output. This circuit features both optical and acoustic indications to enable the driver to change gear at the optimum time in order to keep the engine speed within its most efficient range.	
draught detector	11-08
However well insulated you think your house is, there are bound to be a few nooks and crannies which will allow interior heat to escape. With the aid of this electronic draught detector they will be found quite easily and the results may surprise you.	
how to recycle dry cell batteries	11-10
energy saving know how	11-13
The 'energy crisis' sounds as familiar to our ears as VAT - its something we have to cope with every day of our lives. It makes sense to save energy but a clear indication as to how and where it could be saved in the home is rarely given. This article takes a look at the central heating system, one of the largest domestic energy consumers.	
simple fuel economy meter	11-16
A meter indicating fuel consumption on a digital display while the car is moving would appear to be a popular project. With the aid of the modules described in this article it should be possible to use any transducer.	
automatic pump control	11-25
In most central heating systems the pump has to work continually both day and night. Considering that a small pump can use up to 100 watts, it can be seen that the automatic control featured in this article is a good investment.	
long life technique in light bulbs	11-28
The standard household light bulbs currently on the market are designed to last about 1000 hours. Where bulb failure can lead to security risks or high maintenance costs, it would be an advantage if their life could be extended. How this can be done without cutting down on light level too much can be discovered in this article.	
automatic curtain control	11-30
fridge alarm	11-34
Modern fridges contain thick layers of insulation to keep the cold in and the heat out. Even so, if the door is left open for longer than necessary no amount of insulation will keep costs down. With this circuit the fridge will complain loudly on its own accord if the door remains open for too long.	
know the ins and outs of your central heating system	11-36
Most people may consider that their system is working perfectly but in practice things have been found to turn out quite differently.	
missing links	11-38
energy saving motor control	11-39
Improved motor control circuits can cut down consumption down by 50% as this article shows.	
coffee machine switch	11-42
With the aid of the circuit presented in this article your coffee maker can save energy by switching off its hot plate when the coffee pot is picked up. It then gives a warning signal so that if the remaining coffee is to be kept warm a button must be pressed.	
operational hours counter	11-44
market	11-47
advertising index	UK-24

contents

conten
cont
con

Handwritten signature: W. van der Horst
11/10

EDITOR:

W. van der Horst

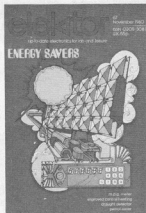
UK EDITORIAL STAFFT. Day E. Rogans
P. Williams**TECHNICAL EDITORIAL STAFF**J. Barendrecht
G.H.K. Dam
P. Holmes
E. Krempelsauer
G. Nachbar
A. Nachtmann
K.S.M. Walraven

**DMM
BREAKTHROUGH**

If you want an
Autoranging
3½-digit LCD DMM

For only

£39.95

(inc VAT)

**We've got
to hand it to you!**

- * ZERO ADJUSTMENT
- * 3½-DIGIT LCD WITH
200 HRS CONTINUOUS
BATTERY LIFE
- * AUTO 'BATT'
WARNING

- * FULL AUTORANGING
- * AUTO UNIT DISPLAY
- * CONTINUITY TEST
(6110 and 6100 only)
- * 10 AMP AC/DC (6110
and 6220 only)

Introducing the latest professional state-of-the-art 3½-digit DMM - at really old-fashioned prices! From just an unbelievable £39.95 inc. VAT, plus £1.15 p&p!

	6100	6110	6200	6220
RESOLUTION	1mV, 10µA, 0.1Ω on all models			
FULL AUTO RANGING	✓	✓	✓	✓
RANGE HOLD	✓	✓	✓	✓
UNITS OF MEASUREMENT DISPLAYED	mV, V, mA	mV, V, mA, A	mV, V, mA	mV, V, mA, A
FUNCTIONS DISPLAYED	SI, KΩ, AUTO, BATT, ADJ, LO, - and AC			
MEASURES DC VOLTAGE TO	1000V	1000V	1000V	1000V
MEASURES AC VOLTAGE TO	750V	750V	750V	750V
MEASURES AC DC CURRENT TO	200mA	10A	200mA	10A
ZERO ADJUSTMENT	Zeroes out minute test-lead resistances for precise measurements			
ACCURACY	0.5%	0.5%	0.8%	0.8%
LOW POWER OHM RANGES	For in-circuit resistance measurements on all models			
BUZZER - Continuity Test	✓	✓	✓	✓
BUZZER - Over Range Indicator	✓	✓	✓	✓
COMPLETE WITH	Batteries, pair of Test Leads, Spare Fuse, One Year's Guarantee			
PRICE	ONLY £64.95	ONLY £76.95	ONLY £39.95	ONLY £49.95
p&p	£1.15	£1.15	£1.15	£1.15

Why such a low, low price? Because the A/D converter and display are custom built! This is a genuine top-spec DMM. Check these features for unbeatable value - you won't find a hand-held DMM with these features at these prices again!

I believe you! Please send me the DMM's as marked.

_____ 6200 @ **£41.10** each, inc. VAT, p&p. Total price £ _____
 _____ 6220 @ **£51.10** each, inc. VAT, p&p. Total price £ _____
 _____ 6100 @ **£66.10** each, inc. VAT, p&p. Total price £ _____
 _____ 6110 @ **£76.10** each, inc. VAT, p&p. Total price £ _____

Total cash/cheque enclosed £ _____
 Cheques payable to
 Maclin-Zand Electronics Ltd., please

Available from the company that gives you tomorrow's technology today, and from other reputable dealers, 38 Mount Pleasant, London WC1X 0AP
 Tel: 01 278 7369/01 837 1165.

ACCESS orders taken. Please write card no. and signature.

ACCESSNO _____ 

Name _____

Address _____

Signed _____

ME

Maclin-Zand

Making state-of-the-art affordable.

To: Maclin-Zand Electronics Ltd., 38 Mount Pleasant, London WC1X 0AP
 Allow 4 to 6 weeks for delivery. For overseas orders, please add £5 to cost of total order package.

2E

3½ DIGIT LCD MULTI-METER KIT

NEW

Build the Practical Electronics handheld DMM. This superb product offers professional precision with extended battery life. Five function operation (AC and DC VOLTS, AC and DC CURRENT, RESISTANCE) with ability to check diodes. 0.5" LCD display with 'Battery Low' warning. Auto-polarity, Auto-zero. Full protection against transients and overloads with ability to withstand mains on any range. 0.5% basic DC accuracy and 15 different ranges. It measures AC/DC voltages from 0.1mV to 500V. AC/DC current from 0.1µA to 2A. Resistance from 0.1Ω to 2MΩ. 200 hour battery life.

The Kit contains all parts needed to construct the multimeter plus assembly instructions, battery and test leads.

We also offer a calibration service (£5.00 + VAT) and a trouble-shooting and calibration service (£7.50 + VAT). Various other component parts are also available as listed.

The multimeter is also available fully assembled and calibrated at a cost of £39.70 + P&P + VAT.

Lascar Electronics Ltd., Unit 1, Thomasin Road, Basildon, Essex. Telephone No: Basildon (0268) 727383.

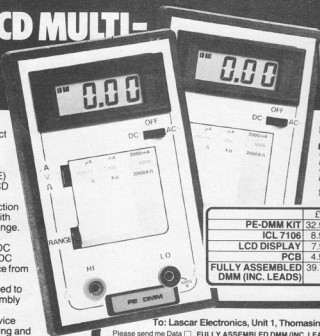

**FEATURED
AS A
PROJECT IN
PRACTICAL
ELECTRONICS**

	£	P & P	VAT	TOTAL
PE-DMM KIT	32.95	1.00	5.09	39.04
ICL 7106	8.95	0.50	1.42	10.87
LCD DISPLAY	7.95	0.50	1.27	9.72
PCB	4.95	0.50	0.82	6.27
FULLY ASSEMBLED DMM (INC. LEADS)	39.70	1.25	6.14	47.09

To: Lascar Electronics, Unit 1, Thomasin Road, Basildon, Essex.

Please send me Data FULLY ASSEMBLED DMM (INC. LEADS) £47.09

PE-DMM KIT £39.04 ICL 7106 £10.87 LCD DISPLAY £9.72 PCB £6.27

Name _____

Address _____

Tel. No. _____

I enclose cheque/P O value _____

for your copies of Elektor —

This cassette style binder will help to keep your copies of Elektor clean and in order, even though you refer to them time and time again. The chamfered corner of the cassette allows instant recognition of each month's issue without the need to thumb through pages of previous months' issues. Because no wires or fastenings are used copies can be easily removed and replaced and each cassette will hold one year's volume of Elektor. Their smart appearance will look good on any laboratory shelf.

PRICE £2.60 inc. postage & packing available from —
Elektor Publishers Limited,
10 Longport,
Canterbury,
Kent CT1 1PE.

please use the order card in this issue.

THE ELEKTOR CASSETTE-BINDER

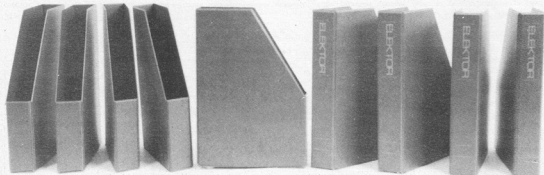

selektor

Car with hybrid drive

A team of leading automotive and technology firms from the U.S., West Germany, and Japan is currently producing two advanced 'hybrid' automobiles for the U.S. Department of Energy (DOE).

The experimental vehicles will have both a gasoline engine and an electric motor under the bonnet. They will run part of the time on gasoline, part of the time on batteries, and — when needed — on both simultaneously.

This is part of an overall DOE programme aimed at stimulating commercialisation of electric and hybrid vehicles as a means of reducing U.S. petroleum consumption. The hybrid design, for example, is expected to consume from 40% to 55% less petroleum than a conventional car of similar size over an 11,000-mile annual driving mission.

General Electric will provide expertise on the electric propulsion motor, the electronic controls for the motor, and the microcomputer controls for the entire hybrid system. Last year, the company delivered to DOE the Electric Test Vehicle-1, the nation's most advanced experimental electric vehicle. Major subcontractors to GE in the hybrid vehicle project are the Research Division of Volkswagenwerk AG, Wolfsburg, West Germany, which will design and build the specially modified gasoline engine; Globe-Union Inc., Milwaukee, Wisconsin, which will develop the advanced 12-volt lead-acid batteries that will power the electric motor; and Triad Services, Inc., Michigan, which will design and fabricate the body and chassis.

These companies worked together pre-

BATTERIES FOR SUPPLY OF ELECTRIC MOTOR

HEATING SYSTEM

4 CYLINDER PETROL ENGINE

30 kW ELECTRO MOTOR/GENERATOR

PETROL TANK

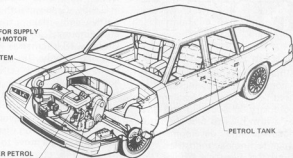

viously, in similar roles, in developing the ETV-1, as well as the GE-100 — an electric test car built from one-the-shelf components.

Daihatsu Motor Co. Ltd., Japan's leading manufacturer of battery-powered vehicles, will serve as a consultant on the project. The Osaka-based company has built more than 4,000 electric and hybrid vehicles since 1965.

Thanks to its dual drive system, the hybrid automobile is a promising approach to helping the U.S. meet its transportation requirements in the potentially fuel-short years that lie ahead. The hybrid car is designed to minimise trips to the gas station and maximise the use of the wall plug for the typical American driver. Its major advantage is that it burns less gasoline than conventional cars, but offers a much greater range than all-electric vehicles.

The hybrid's electric motor and gasoline engine will operate separately or in parallel. The electric motor will primarily be used for speeds from zero to

30 mph and the gasoline engine for most highway driving. In situations where both the electric motor and the gasoline engine are needed, such as in overtaking, the load will automatically be shared. A microcomputer will control overall vehicle operation.

The baseline vehicle selected by GE for this project is a mid-size, four-door car. It will utilise front-wheel drive, with the internal combustion engine and electric motor mounted longitudinally under the bonnet. The complete power train, including batteries, will all be located in front of the forward bulkhead. In addition, the vehicle's exterior will be redesigned for improved aerodynamics.

Curb weight of the car is estimated to be about 3,950 pounds. The vehicle will be equipped with an automatic three-speed transmission. The car's ten batteries will have a total weight of 770 pounds, and will have a life expectancy of approximately 800 recharge cycles. The battery pack may be recharged by regenerative braking, by the gasoline engine when it is in operation, and by wall-plug electricity.

Although the hybrid will weigh about 800 pounds more than its conventional counterpart, its dual propulsion system will require 5% less total energy.

It is estimated that the experimental hybrid auto will accelerate from zero to 50 mph in 12 seconds and will look, perform, and handle like conventional vehicles that will be marketed in the mid-1980s. Its design is planned to be suitable for mass production in the mid-1980s at a consumer price of about \$7,600 (1978 dollars).

Although no plans at this time exist to manufacture or market electric or hybrid vehicles, long-range opportunities to supply components for the emerging electric and hybrid-vehicle market are foreseen.

A report by General Electric, Schenectady, N. Y.

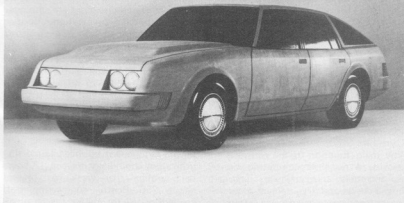

selektor

Electronics in Livingston

Recent major developments by electronics companies in Livingston have emphasised the town's leading role in this industry in Scotland and given the town a firm base to face the future and encourage the development of further high-technology industries.

Throughout this year, electronics firms have shown by their development programmes that Livingston is an ideal location for their operations — be they manufacturing, research and development, or sales.

Two American-owned companies, Burroughs Machines Ltd and MFE Ltd have moved over the summer period into purpose-built manufacturing plants on Kirkton Campus, a special industrial area of 80 hectares which Livingston Development Corporation set up for companies with a high research or technological content in their operations and with the need to have close liaison with universities.

A third American company, Guardian Electric of Chicago, have established their European sales and marketing headquarters in an office block in the town.

The Burroughs factory, on a 5½ hectares site, manufactures data processing equipment for the banking industry and is building up its workforce in the 8,350 square metres factory to around 200 people — many of them university graduates and highly skilled workers.

On a nearby site, MFE Ltd have moved into a 2,270 square metres factory — their first manufacturing plant outside North America. They employ around 60 people and aim to increase this to 240 by the end of the next five years.

At Livingston they manufacture and market computer peripheral devices, including the high technology floppy disk drive. The success at Guardian Electric Sales and Marketing Co. Ltd., has exceeded the company's expectations since they moved into Peel House, Ladywell, in March.

Another well-known name to opt for Livingston when looking for a location for a research establishment was Ferranti, who announced earlier this year that they would move their computer graphics design facility from Edinburgh to an advance factory on Brucefield Industrial Park, Livingston.

The great majority of new companies moving to the town in both the industrial and commercial spheres originate from outside Scotland, attracted by Livingston's attractive amenities, its superb links with airports, container ports, railheads and motorways.

The hard commercial facts are that

Livingston is demonstrably the main industrial growth point in Central Scotland, with easy access to deep water port and container facilities at Leith, Grangemouth and the Clyde ports, and major freight terminals at Edinburgh, 24 kilometres east, and Glasgow 48 kilometres west. Edinburgh Airport is only 15 minutes away by road, and every UK international airport is within 60 minutes flying time. These, in addition to Livingston's situation on the M8 Motorway, are powerful factors in favour of Livingston as a new location for an industry contemplating a move to Scotland.

Of the 145 companies already established in Livingston, more than 20 are involved in the electronics industry. The town's popularity with the electronics industry was explained by Mr I.B. Alexander, engineering director of Marconi Communications Systems Ltd., who relocated a research and development facility in Livingston at the end of 1977.

Livingston he said, was ideally situated near Scotland's major universities, and the company had found that there were a lot of graduates emigrating from Scotland. A lot of companies coming to Scotland were not giving the right type of work for these graduates and there was a need to provide an outlet.

Marconi wanted an operations base in central belt of Scotland and Livingston's ideal position gave it a very important advantage.

Livingston is within easy reach of seven of Scotland's universities. It has particularly close links with Heriot Watt University, which is less than ten minutes away by car. Also in close association is the Science Faculty of Edinburgh University.

University/industry liaison is also maintained with Strathclyde University, Glasgow, which has established a Centre for Industrial Innovation.

(572 S)

selektor

New computing centre at Bristol

Since the beginning of the year a new £2 million computing centre housed in a purpose-built building has been in operation at British Aerospace Dynamics Group Bristol Division.

The main function of the centre is to provide a real-time computing service to scientists and engineers engaged in the design and development of guide-weapon and space engineering systems.

The computer is an IBM 3031 with a 4Mb mainstore. Also included in the installation are eight IBM 3350 fixed disc drives and six IBM 3330 demountable drives giving a total on-line storage-capacity of 3,736 Mb; plus four magnetic-tape drives, a card reader/punch, two line printers and an IBM 3705 communications controller to which are linked two remote batch terminals and 40 individual input/output terminals.

The Bristol computer is connected via two 9600 baud channels to another British Aerospace Dynamics Group computer — an IBM 370-158 AP (shortly to be replaced by an IBM 3033) — situated at Stevenage which primarily performs commercial tasks with peripheral units of the Bristol installation being used for data input and output. In addition, the Bristol Division's remote batch terminals can be switched over two more channels to connect with another Dynamics Group computer (an IBM 370-158) for engineering and scientific work.

The Bristol centre is operated by the 69-member staff of the Management Services Department as a general service to the British Aerospace Dynamics Group Bristol Division, computing time being logged and charged to the user departments. The key to the operation of the Bristol centre is the 40 individual input/output terminals which are distributed throughout the many sites the Division has in the Bristol area. Each input/output terminal consists of a visual display unit (VDU) with an associated keyboard. With the aid of such a terminal a scientist or engineer can develop and run his own programs in real-time calling up information or other set programs held in the computer's store files when needed, as though he were the sole user of the computer system. The computer is under the general control of MVS/SE (Multiple Virtual Storage/System Extensions) and the operation of the VDU terminals is organised by the VSPC system (Virtual Storage Personal Computer). Fortran, in its various dialects, is the language used for scientific and engineering applications; commercial programs are written in Cobol.

Nine Redifon Seecheck terminals linked to a 5 Mb fixed-disc store are employed for input data preparation. Verified data is transcribed from the disc store to magnetic tape for entry to the computer. Input data for commercial programs is mainly prepared this way. The smaller volumes of input data required for technical programs, or amendments, are usually presented on punched cards prepared by the individual users.

To avoid the need for engineering users having to queue it has been found that utilization should not exceed 12 hours per terminal per week. At present about 250 Bristol engineering staff are authorised to operate the terminals

but this number is increasing rapidly as engineers gain experience in computer usage.

To increase the Division's overall data processing capability the possibility of linking other calculating devices to the central computing installation is being investigated whereby the centre would provide the needed back-up capacity to ancillary units in danger of becoming overloaded. Such ancillary units would be programmable calculators and minicomputers dedicated to particular tasks, such as recording data of structural tests etc.

A scientific computing service based on the Stevenage machines has always been available to the Bristol engineering staff and over the last three years the demand for such services has increased at an annual rate of 25%. This was the reason the new computing centre was established at Bristol and the initial experience is that this growth rate will continue, necessitating the addition of an extra 2 Mb of main store and at least another 10 terminals to the installation by 1981.

In addition to VSPC, terminals can operate with TSO (Time Sharing Option) which makes greater demands upon computing time. A VSPC user utilises about 1% of the existing computing capacity whereas for a TSO user the figure is nearer 4%. On this basis it is estimated that by strictly limiting the number of TSO terminal users, as many as 60 VSPC terminals could be supported by the existing installation.

Nowadays the computer is an essential tool of scientists and engineers engaged on advanced technological projects whether they are concerned with defence or space. The reason is that the costs involved and the time-scale in which projects have to be completed place increased emphasis on the engineering solutions being right first time.

The traditional engineering technique of building a prototype which is extensively tested and modified before the first production model is built is no longer acceptable — this process is too slow and too expensive. Hence more detailed theoretical calculations have to be performed simulating the actual response to the expected from the structure, equipment or system being designed, in all possible operational situations long before the decision to build is taken.

A computer is the only means by which data covering all aspects of a design can be derived for the worth of a particular solution to be evaluated in the time allowed for the project. A typical example of the type of problem that needs to be investigated in this manner could be assess flexural modes and structural integrity resulting from differential heating by the sun of a proposed space structure exposed at varying attitudes to the sun. Accurate knowledge of these effects is particu-

larly important since only one or two units will be built, therefore the margin for error is extremely small.

British Aerospace Dynamics Group Bristol Division is primarily concerned with the design and development of naval guided weapon systems (Seawolf and Sea Dart) and scientific space satellites and equipment including solar power arrays, attitude and orbit control systems, a range of HF antennas for aircraft and military vehicles.

(579 S)

selektor

Digital signal processor chips spur SP market growth

Stimulated by strong military spending on radar and sonar signal processing, the development of ultra-high-speed signal processing chips will accelerate in the 1980's, according to a new 141-page report from International Resource Development Inc. The IRD report predicts 'major' technological fallout in the commercial-electronics market, particularly in medical, telecommunications and automotive applications. A doubling of the signal processing market (currently \$1 billion) is expected within three years.

Rapid progress in array processors, charge devices, surface acoustic wave gear

Array processors are now being made for 'front-end' processing of signals which are destined for later processing in digital computers, according to the IRD report, which points to the recent link between Computer Signal Processor and Systems Engineering Laboratories in the marketing of a powerful combined signal-processing/data-processing system. But the fastest progress in signal processing technology is probably occurring in the area of Charge Coupled Devices (particularly CCD transversal filters) and in the development of Surface Acoustic Wave (SAW) devices. And although the work being done on electronic countermeasures is 'hush-hush', the IRD researchers believe that the military signal processing know-how is trickling down very rapidly into the commercial sector of the electronics market.

Major commercial applications in medicine, telecoms, automobiles

Signal processing technology has played a critical role in the development of Computerized Axial Tomography (CAT) scanners, and is now contributing to

the rapid growth of ultrasound and infrared medical imaging equipment markets, says the IRD report. Digitization of speech, store-and-forward voice switching and other important telecommunications applications have also resulted from the continuing fallout of military signal processing know-how. One of the major commercial applications of signal processing technology in the 1980's will be the use of LSI chips as part of on-board automotive electronics systems, where fuel consumption and exhaust emissions are continuously monitored. Some of the signal processing techniques used in this application are direct offshoots of military SP technology.

Countermeasures, sonar, 'smart' weapons to pace military SP market

The continuing race to develop electronic equipment capable of fooling enemy radar and weapons guidance devices has acted as a major stimulant to the signal processing market during the past twenty years, according to the IRD report, and has resulted in the production of low-cost, ultra-fast LSI signal-processing chips, which are key components in 'black box' devices. These 'black boxes', produced by such companies as Loral and E-Systems, have become essential to modern warfare, and future advances in the detection of submarines and in 'smart' weapons will be largely dependent upon the U.S. semiconductor equipment manufacturers' ability to stay ahead of Russian signal processing technology.

The IRD report identifies more than one hundred U.S. companies active in the market for signal processing components or systems. Technological leaders, according to IRD, include E-Systems, Time & Space Processing, Bell Labs, Loral and Bendix. Several semiconductor suppliers, including Advanced Micro Devices, Intel, National Semiconductor, Signetics, Standard Microsystems and Zilog, are also identified as being very active in the development of new-generation signal processing chips.

International Resource Development Inc. is an independent consulting firm which, since 1971, has been publishing research reports covering developments in the computer and telecommunications fields. IRD has also undertaken custom consulting studies for many high-technology firms, including Texas Instruments, Rockwell International, IBM and Xerox.

(573 S)

selektor

an R.P.M. indicator as an economy guide.

fuel economiser

A car engine is at its most efficient when the amount of energy it produces is closest to the amount consumed. This occurs at an engine speed that produces the maximum torque output. Outside of this quite small speed range energy is wasted. The fuel economiser provides both an optical and an acoustical guide to enable the driver to change gear at the optimum time and thereby keep the engine within its most efficient range.

Although an r.p.m. counter is a useful instrument, it is not very helpful in terms of saving petrol. If it was to be used for this purpose it would have to be watched far too carefully to be effective and this would be too demanding on the driver. The circuit described here does not provide a complete r.p.m. indication but rather an indication of when to change gear in order to keep the engine speed at its most efficient. It also gives a warning when the maximum engine speed is approached and would therefore be of use to drivers of high performance cars as well.

The circuit has been designed to demand as little attention as possible

from the driver. As well as giving a visual indication in the form of coloured LED's, it is able to produce an audible indication of the correct gear change times.

How an r.p.m. counter can help save fuel.

It is often underestimated how much a person's driving style will affect fuel consumption. Figure 1 shows the factors which are involved. The consumption of a car without any technical defects has been set at 100%. The 'extra's piled onto that block should be avoided, and it is the 'driving style' section which depends exclusively on the driver.

As far as driving economically is concerned, this is easier said than done. Usually, we drive 'by ear' which is not always an objective method. An r.p.m. counter is highly objective and can help break some bad habits.

The amount of energy consumed by the engine is largely dependent on the engine speed and the torque. Figure 2 shows the torque/revs curve of a typical engine with the energy consumption as a function of the r.p.m. The engine will produce the maximum amount of torque at a certain number of revs. (The exact amount will of course depend on the engine). At this speed, the engine will be running at its highest efficiency. When engine speed is increased significantly above this figure however, much more fuel will be consumed, with a progressive decrease in actual power output per 100 r.p.m. From the graph the following guidelines for an economical driving style may be deduced:

When accelerating (particularly in town traffic) the engine speed in every gear should reach the point at which the maximum torque occurs. As soon as this

speed is exceeded, the driver should change gear.

- When accelerating depress the accelerator smoothly and not too quickly.
- The key to success is to accelerate smoothly and change gear on time.

When the car is not accelerating, it will be apparent that the higher the gear, the lower the fuel consumption. (For in a high gear the number of revs will be lower and as figure 2 shows, fuel consumption is at a minimum at low engine speeds).

The number of revs should not exceed the level at which the maximum amount of torque is produced. Unfortunately, prevailing these measures will be affected by traffic conditions. However, any attempt at saving fuel and whenever possible must be better than no attempt at all. This is where the Fuel Economiser becomes really effective.

Which r.p.m. counter?

Of course any r.p.m. counter can be used to save energy. Unfortunately, as mentioned previously, the 'ordinary' type using a dial or, even worse, a digital display demand too much of the driver's attention. An r.p.m. counter which is meant to save fuel should only provide relevant information when required and not in such a way that the driver is distracted. It is better for it to indicate ranges rather than exact values. In the Fuel Economiser these are indicated by LED's in the following manner;

- yellow: engine speed lower than at maximum torque
- green: engine speed about right for maximum torque
- red: engine speed higher than maximum torque

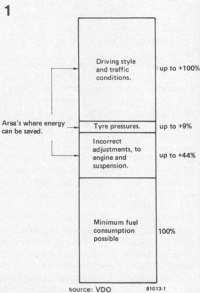

Figure 1. People underestimate how much their driving style can affect the fuel consumption. Even so, this has been known to differ by 100%.

2

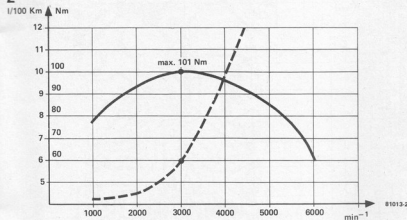

Figure 2. Consumption and torque as a function of the number of revs.

3

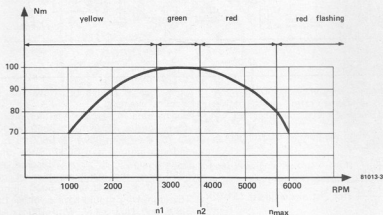

Figure 3. The fuel economiser does not indicate the exact number of revs, but gives a general idea of whether they are too low, too high or just right.

4

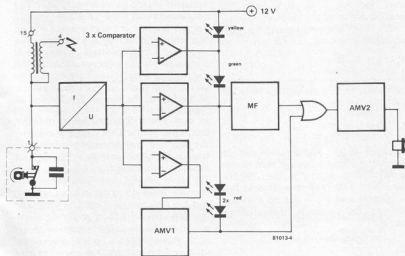

Figure 4. The block diagram.

red flashing: maximum permissible engine speed reached

Figure 3 shows how the display works in relation to the torque/rev curve. Three LED's are sufficient. An extra acoustic signal means you don't have to keep your eye on the LED's continuously. A short tone signals the transition from the green to the red range and indicates it is time to change gear. When the maximum number of revs is exceeded an intermittent warning note will be produced.

The fuel economiser itself:

The block diagram shows a frequency-to-voltage converter at the input to convert the contact breaker frequency into a linear, proportional DC voltage level. This is fed to three comparators which are used to switch the corresponding LED on when the measured engine speed complies with the preset threshold value. When the light switches from green to red, the monoflop MF sends a pulse to the tone oscillator AMV2, which then produces an acoustic signal with the aid of a loudspeaker.

When the threshold value for the maximum number of revs is reached AMV1 is triggered and produces the flashing frequency for the red LED. At the same time this signal is used to switch the output of the tone oscillator via an OR gate.

As can be seen in the circuit diagram (figure 5), the frequency-to-voltage converter is a fairly simple circuit. Transistor T1 acts as a pulse shaper and IC1 is a 555 timer IC in a monoflop configuration. By integrating its output with the two RC networks R7/C6 and R8/C7, a DC voltage level that is proportional to the pulse frequency is obtained. This DC level will arrive at the non-inverting inputs of op-amps A1...A3. These three op-amps are used as comparators and are, together with A4, combined in a single LM324 IC. The voltages to be compared are adjustable with preset potentiometers P2...P4. Until one of the threshold values is reached, (the number of revs being below the economical value) the outputs of the three comparators will be low. In this condition the yellow LED D7 will light and the others will remain unlit.

When the first threshold is reached (lowest limit of the maximum torque range) the output of A1 will be at the positive supply voltage (about 12 V); causing the green LED (D8) to light and D7 to go out. At the second threshold A2 will switch, the green LED will go out and the red LED's D9 and D10 indicate that the torque output is falling. The positive edge of this signal triggers the tone oscillator. Integration through C11 and R19 causes a tone with a descending pitch to be produced. This is to advise the driver to change to a higher gear.

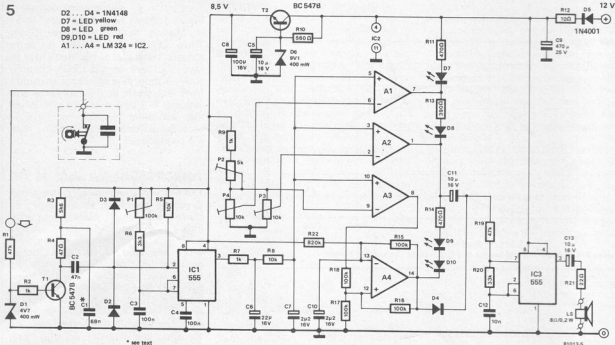

When the engine speed reaches the value set by P2, comparator A3 will switch on the astable multivibrator A4. This will cause the red LED's D9 and D10 to flash once every second and modulates the tone oscillator IC3 via D4 to give an intermittent warning signal. IC3 controls an 8 Ω/0.2 W loudspeaker. If a greater volume is required, a piezo tweeter can be used instead. If the volume is too loud, R21 can be increased.

To enable the fuel economiser to work efficiently in the car a voltage stabiliser is needed and this consists of zener diode D6 and transistor T2. Diode D11, resistor R12 and capacitor C5 serve to suppress transients.

Construction and setting up

Thanks to the printed circuit board shown in figure 6, construction should pose no problems. It is advisable to use sockets for the three IC's. It is also an advantage to use tantalum electrolytical capacitors for C7, C10 and if possible for C14 and C11 too.

Setting up requires a multimeter, a small transformer and a bridge rectifier. In addition, the following engine data should be obtained:

1. The highest acceptable engine speed in r.p.m. (n_{max}). This can usually be found in the car manual but if in doubt, 5,500 r.p.m. will be close enough. To save the engine a slightly lower figure should be taken, say about 5,250.
2. The lowest ($n1$) and highest ($n2$) limits of engine speed are derived from the engine torque/rev curve (see figure 3). If this is not given in the manual, you should ask your car dealer.
3. The number of revs at a contact

breaker frequency of 100 Hz. The following ratio exists between frequency f (Hz), number of revs

n ($\frac{1}{min}$) and the number of cylinders Z :

$$f = \frac{n \cdot Z}{120} \quad (\text{for 4-stroke engines}) \quad \text{and}$$

$$f = \frac{n \cdot Z}{60} \quad (\text{for 2-stroke engines}).$$

From this it follows that for 100 Hz in a 4-cycle engine $n_{100 \text{ Hz}} = \frac{12000}{Z}$ is required.

Once these r.p.m. values have been calculated, the voltage value can be preset for n_{max} at 5 V with P2 measured either at the rotor or at pin 9 of IC2). The following voltage for $n2$ is then preset at the rotor of P3:

$$U_{P3} = 5 \cdot V \cdot \frac{n2}{n_{max}}$$

Analogous to this the voltage for $n1$ is preset at the wiper of P3:

$$U_{P4} = 5 \cdot V \cdot \frac{n1}{n_{max}}$$

Finally, the frequency-to-voltage converter will have to be adjusted to the engine's r.p.m. For this the 100 Hz generator (figure 7) is connected to the rev counter and P1 is set so that the following DC level is measured at capacitor C7:

$$U_{C7} = \frac{n_{100 \text{ Hz}}}{n_{max}}$$

The value of C1 is calculated for the maximum revs per minute (4 cylinder 4-stroke).

That covers regulation. Now for a practical example.

Engine data: 4 cylinder 4-stroke, maximum torque 101 Nm at 3800-4600 r.p.m., maximum power at 5800 r.p.m. and maximum r.p.m. 6600. Since the greatest power is already reached at 5800 revs, the maximum number of revs (5 V at P2) is set at 6000 r.p.m. Therefore U_{P3} should have a voltage of 3.8 V and U_{P4} 3.1 V. With 100 Hz at the input P1 is adjusted to a voltage of 2.5 V across C7.

Hints on building the circuit into the car

The circuit can be mounted in a standard plastic or aluminium case. The connection of the positive supply voltage is made at a convenient point on the ignition switch or the fuse box. The negative supply voltage (ground) is connected to the closest earth point (in cars with the negative of the battery to earth). The input of the circuit will be connected to the contact breaker side of the coil.

In cars where the connecting pins are according to the DIN 72552 standards, the positive supply voltage is derived from pin 15, the earth from pin 31 and the contact breaker from pin 1.

To avoid interference from radio, the connection between the contact breaker and the rev counter should be laid close to metal parts of the bodywork. Even better would be to use a cable with an earth shield. Make sure that the wiring does not touch any 'hot parts' of the engine.

If after fitting the display should 'jump' and the circuit shows a false alarm once or twice, the value of R1 may be

6

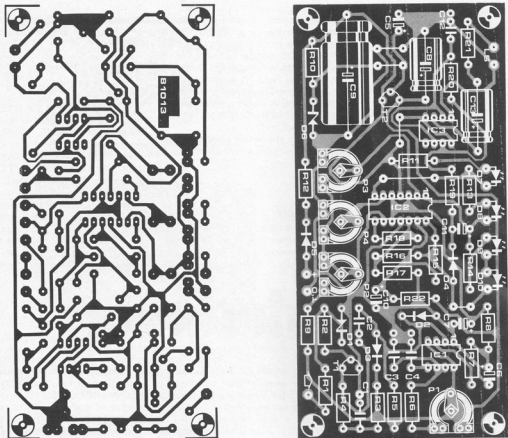

Figure 6. The component layout of the printed circuit board.

Parts list

Resistors:

R1, R19 = 47 k
 R2, R7, R9 = 1 k
 R3 = 5k6
 R4 = 47 Ω
 R5, R8 = 10 k
 R6 = 3k3
 R10 = 560 Ω
 R11, R14 = 470 Ω
 R12 = 10 Ω
 R13 = 390 Ω
 R14 = 470 Ω
 R15, R16, R17, R18 = 100 k
 R20 = 33 k

R21 = 22 Ω
 R22 = 820 k
 P1 = 100 k preset
 P2 = 5 k preset
 P3, P4 = 10 k preset

Capacitors:

C1 = 68 n
 C2 = 47 n
 C3, C4 = 100 n
 C5, C11, C13 = 10 μ /16 V
 C6 = 22 μ /16 V
 C7, C10 = 2 μ /16 V
 C8 = 100 μ /16 V
 C9 = 470 μ /25 V
 C12 = 10 n

Semiconductors:

T1, T2 = BC 547B
 IC1, IC3 = 555
 IC2 = LM 324, CA 324
 D1 = zener diode 4V7/400 mW
 D2, D3, D4 = 1N4148
 D5 = 1N4001
 D6 = zener diode 9V1/400 mW
 D7 = LED yellow
 D8 = LED green
 D9, D10 = LED red

Loudspeaker:

LS = 8 Ω /0,2 W

lowered to a minimum of 4k7. It is also possible that P1 is incorrectly preset and so has to be readjusted.

Guarantee for economy

It is difficult to determine how much fuel an economiser circuit could save, because the consumption does not depend on the circuit, but on the driver. The circuit will merely give a helping hand. If the driver is prepared to be 'advised' then some reduction in consumption is bound to be achieved. Naturally, a driver who is converted from a 'quick-off-the-mark' speeder to an energy-heeder will save a great deal more than someone who drives economically anyway. In any case, much

7

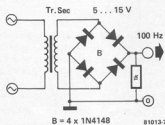

Figure 7. A very simple '100 Hz generator'.

more will be saved in town traffic than on the motorway.

One guarantee can be given for certain and that is that it is considerably cheaper to use a fuel economiser than the 'on-board computer' with which cars are likely to be equipped in the near future and which serves exactly the same purpose.

sources:

Dr. E. Spoerer, W. Thieme,
 'The technique to drive economically'
 VDO Vertriebsgesellschaft mbH,
 Postfach 2220,
 6232 Bad Soden 2.
 Elektor no. 17 (September 1976),
 'Rev counter'.

There are many elementary ways of checking for draughts in a house. You can, for instance, moisten a finger and hold it up in the air to see from which direction the wind is blowing. Another method is to wander around with a burning match or candle, but this seems to attract gas leaks (in which case your worries are over) and nasty grease marks on the carpet. A much simpler solution is to use the electronic draught detector described here.

By mounting the sensor on the end of a long probe, no draught will be able to escape undetected.

The principle

The circuit is based upon a very simple principle: when an object is warmer than the surrounding air, it will dissipate heat, especially if the air is moving. The

diode in an open air current is compared to that of a reference diode at ambient temperature an indication of the location and intensity of the draught may be obtained.

The design

How the principle is put into practice in the form of a circuit is shown in the diagram of figure 1. Transistor T2 is connected as a diode and acts as the sensor. Since the sensor must be warmer than the air around it, T1 has been added as a form of 'heater'. These two transistors are literally 'glued' to each other. As T1 has a continuous current flowing through it, it will tend to warm up T2. Transistor T3 is also used as a diode, but it will be at ambient temperature, that is the average room temperature. The output voltages from

draught detector

However well insulated you think your house is, there are bound to be a few nooks and crannies which will allow interior heat to escape. Once they are found they can be dealt with quite easily — it is the act of locating them that is the major cause of headaches! With the aid of this electronic draught detector you can easily trace the source of your stiff neck and keep the house warm.

temperature of the air is raised causing it to move away and be replaced by cooler air. If the temperature difference between the outgoing and the incoming air is great enough, the object will be cooled rapidly. This is in fact why we are able to 'feel' a draught on small areas of our bodies.

It follows then that a draught may be detected electronically by measuring the cooling rate of a semi-conductor. The forward voltage of a semi-conductor diode is temperature dependent ($2 \text{ mV}/^\circ\text{C}$). If the forward voltage of a

T2 and T3 are fed to the non-inverting and inverting inputs respectively of an opamp (IC1). This opamp, and its associated components, is preset for a gain of 1000.

The output of IC1 provides a base drive current for the heating transistor, T1, via resistor R1. This effectively heats up T2 indirectly. There will then be a slight difference in voltage at the two inputs of IC1 (since T3 is not heated). A high sensitivity is obtained by making the temperature of T2 about five degrees higher than its surroundings. This is

1

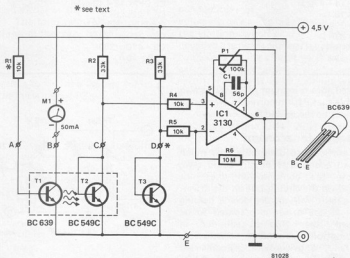

Figure 1. The complete circuit diagram of the draught detector.

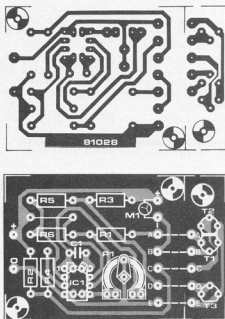

Figure 2. The component overlay and track pattern of the printed circuit board for the draught detector. The three transistors can be mounted on a suitable probe.

Parts list

Resistors:

R1, R4, R5 = 10 k
 R2, R3 = 33 k
 R6 = 10 M
 P1 = 100 k preset potentiometer

Capacitors:

C1 = 56 p

Semiconductors:

T1 = BC 639 (BC 547 can be used, but its connections differ from those on the board)
 T2, T3 = BC 549C
 IC1 = 3130

achieved by presetting the meter to give an offset of about 5 mA by means of P1.

When the sensor is placed in a cold current of air the temperature of T2 will drop. Its output voltage will then rise by 2 mV/°C. The voltage difference at the inputs of IC1 will increase causing its output voltage to rise as well. As a result, the collector current of T1 increases and more heat is generated by this transistor until a new balance is obtained. The meter indicates the increase in collector current and therefore the intensity of the draught.

The value of R1 should be chosen so that the collector current of T1 is not excessive. This is important both for the instrument and for T1!

Construction

All the components (except for T1, T2 and T3) are mounted on the printed circuit board shown in figure 2. Both the meter and the completed board can be installed in the same (small) case.

Transistors T1 . . . T3 are fitted in a sort of probe, a length of tubing (see photo) would be ideal. The two transistors, T1 and T2, are coupled by gluing their flat surfaces together with a heat conducting adhesive.

If the finished circuit tends to oscillate, the value of R5 may be increased. Two 4½ volt batteries, connected in parallel, are all that is required for the power supply.

The sensitivity of the unit may be increased (if required) in two ways: firstly by presetting the quiescent current to a higher value, thereby increasing the temperature of T1/T2. Secondly by enlarging the cooling surface area, for instance by inserting a metal strip between the two transistors. A little experimenting is all that is needed now to prove how useful the draught detector can be . . . according to our chief draughtsman!

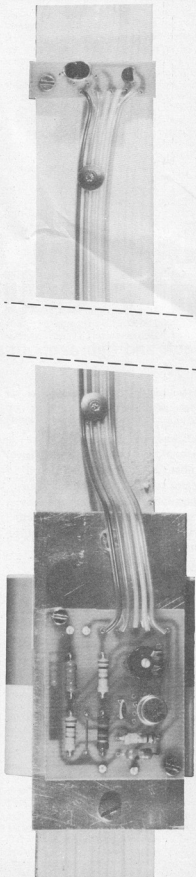

how to recycle dry cell batteries

facts and figures about a controversial subject

'Reviving dry cell batteries' is a topic which often comes up in electronics magazines and professional 'shop-talk'. Remarkably perhaps, so little is known about the subject that it seems to give rise to nothing but speculation. On the basis of our experience with batteries, we will try to establish a few facts to solve the mystery.

To start with, a dry cell battery cannot be recharged like an accumulator.

It is however possible to reactivate dry batteries by means of a corresponding similar 'charge process', that is to say, by reversing the capacitance loss which occurs during discharge to a certain extent. Since 'charging' a dry battery is much more complicated than a nicad cell, it is impossible to revive one when it is almost totally discharged.

The first attempts to regenerate dry batteries date back to the twenties. In the past there were all sorts of devices for this purpose, but their operation usually led to unsatisfactory results, which is why these 'chargers' have all disappeared from the market.

half of the AC waveform. D1 will be high impedance, so that a discharge or 'reverse' current passes across R1 and R2. The value of R2 would normally be ten times the value of R1. The voltage of the recycling current is preset so that the peak value is not higher than the normal voltage of a new cell.

The superimposed alternating current should cause the dissolved zinc to be deposited in a more even and dense layer on the inside wall of the container than when recycling is carried out with a direct current only.

In the Varta battery handbook the procedure for a successful recycling has been summarised as follows:

a. The peak value of the charge voltage

Disposable batteries nevertheless use up a great deal of energy and raw materials, which could be saved by regeneration or electrochemical recycling. Recently, a magazine in East Germany published a series of articles on the subject. Telefunken is manufacturing portable radio's including a recycling circuit called 'long life technique'. Battery manufacturers are also working on recycling projects. One of them, Mallory, has developed a successful alkali manganate battery to be available on the American market soon.

Looking at some specimens

The most well known example is the 'classical' recycling circuit shown in figure 1, for which E. Beer holds a patent.

Basically, this is a half-wave rectifier. The rectified voltage is superimposed with an additional alternating current across R2. During the positive half-wave a charge current flows across D1 and R1 (R2's influence is negligible since it is bridged by D1). During the negative

may not rise above 1.7 V per cell,

b. The recycling current is determined by the size of the cell and should be between 1/4 and 1/3 of the battery's discharge current.

c. The recycling time required is about 4.5 to 6 times the preceding discharge time, as, due to the low efficiency, the reactivating current must be about 50% larger than the amount lost.

d. The shorter the discharge interval, the more effective recycling will be. During a discharge period the battery should only lose a tenth of its total capacity.

e. The battery should best be recycled straight after discharge.

f. When dry cell batteries have been almost or completely discharged, they can never be recycled.

As far as the optimum size and efficiency of reverse current components is concerned (current across R2 in the basic circuit) opinions differ widely. Telefunken, for instance, finds that equally good results may be obtained using direct current only, since in practice recycling is very hard to achieve anyway. With regard to the results there is also a good deal of disagreement. Some say the capacitance is increased by a factor of 3 and others by a factor of 30 (!). The true level should be somewhere in between the two. In any case, the results depend on the 'circumstances' (the size of the battery, the type of battery, duration of the charge and discharge periods, interval between charging and recycling, etc.). One thing however is certain: recycling lengthens a battery's life-span.

1

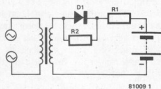

Figure 1. A simple but effective recycling circuit.

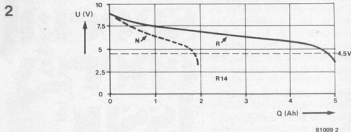

Figure 2. Tests show that recycling can increase the operational hours of a penlight cell by a factor of 3.

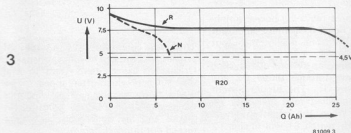
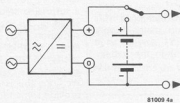
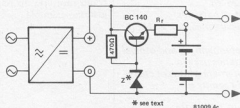

Figure 3. Recycling tests on a standard cell showed an increase of up to a factor of 4 in the operational hours count.

4a



b



c

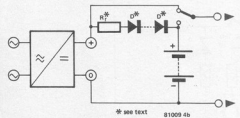

Figure 4. These circuits can be used to extend the life of batteries in portable equipment provided they have a built in mains power supply. Changeover from mains to battery (a) can be automatic via a mains connection socket switch.

Which batteries can be recycled?

Generally speaking, most types of zinc carbon batteries ('normal' dry cells) can be recycled with successful results. This is not the case with 'high power' batteries since tests on these have proved inconclusive.

The alkali manganese and mercury types should also be able to be recycled, but so far experiments have come up with nothing definite. It is not advisable to try recycling mercury batteries due to the danger of poisoning when mercury leaks out. Even more dangerous, in fact lethal, would be to recycle lithium cells - these are highly explosive!

Tests

It might be interesting at this stage to examine the tests carried out at Telefunken and the results that were obtained.

During an extensive series of experiments six batteries (nominal voltage 9 V) were subjected to four hours' operation (charging the battery with a charge resistance of 82Ω) and 20 hours' rest every day. The batteries to be recycled were connected to a constant direct voltage of 9.5 V across a charge resistance of 47Ω during the 20 hour period.

From figures 2 and 3 it can be seen that the dischargeable capacitance (operational hours count) in penlight baby cells may be increased by a factor of 3 and in single cells even by a factor of four. The high power type on the other hand showed no increase in capacitance worth mentioning.

All in all, therefore, normal cells can be recycled and used at very low cost per operational hour, provided the equipment they are in is mostly connected to mains.

Circuits

The following circuits to be discussed here were designed on the basis of Telefunken's experiences with direct current charging.

They can be incorporated into any portable device (such as a transistor radio cassette recorder) that includes a built in mains power supply. Switching from battery power to mains can be done either manually or automatically by plugging the supply cable into its socket (see figure 4a). For recycling purposes, the same switch will now be bridged by the charge resistor R_c and the diodes switched in series (see figure 4b). The most important requirement which must be met during recycling is that the charge voltage must not be higher than that of a fresh battery (1.7 per cell) to prevent it from being overcharged. If the open-circuit voltage of the power supply (which must be measured!) is higher, it will have to be limited with diodes to a

It is not common practice for Elektor to be concerned with central heating systems, but the fact is that this is an area where a surprising amount of energy could be saved. Let's look at the following example: in one way or another (the actual method isn't relevant at the moment) 10% could be saved on the gas consumption of the central heating or water boiler. Where the overall annual consumption of a central heating system is 3000 m³ this would mean a saving of 300 m³, whereas in a hot water system that uses 600 m³ up to 60 m³ can be saved.

This article discusses methods of saving

depends on maintenance, the amount of gas burned, efficiency (insulation/lagging) and finally the amount of energy that is lost 'up the chimney'.

Maximum efficiency will be achieved by making sure the burner's air pipes remain clear. It is advisable to leave any adjustments required to the boiler to the professionals — leave well alone! What you can do is check the whole system as follows: take note of the reading of the gas meter and then let the boiler burn for a while, half an hour for instance. The new meter reading will give you an indication of the amount of gas consumed, which

energy saving know-how

The 'energy crisis' sounds as familiar to our ears as VAT — it's something we have to cope with every day of our lives. Although the government seems to be continually harping on the 'save energy' theme, a clear indication as to how and where energy could be saved in the home is rarely given. This article takes a look at the central heating system, one of the largest domestic energy consumers.

energy without modifying the heating system in any way, in other words, without having to invest a penny. Correct adjustment of the system itself is a must!!

The boiler and radiators

First let us see what happens when heat is generated. The gas burned in the boiler heats up water or air which in turns warms up the room via a radiator. The boiler's performance largely de-

should correspond to the figures marked on the boiler. The manufacturer has designed the boiler for a specific gas consumption and any deviation will usually have an adverse effect on the boiler's performance. If there is quite a large difference, you'll have to call in a heating engineer.

When the system was designed, the pipes and radiators were selected to reach a specific temperature in every room. For instance, 15° in the bed-

1

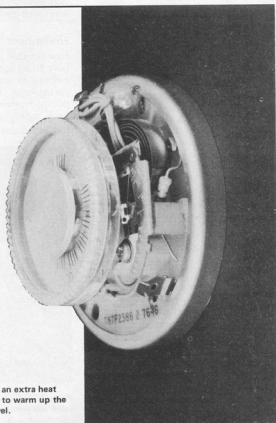

Photo 1. In some thermostats an extra heat source is switched on at night to warm up the thermostat to the required level.

rooms and 24° in the bathroom. Calculations of this type however can only be a close approximation and so to be on the safe side, the radiators are always made slightly larger than necessary. As a result, a number of rooms can get warmer than is strictly necessary and this is usually where a considerable saving could be made.

Nearly all radiator taps can be adjusted. This means the maximum amount of water flowing through the tap can be regulated. So if the room gets too warm, the tap setting will have to be adjusted. Then less water will flow through the radiator and the temperature will drop. You can either let specialists do the job for you (which could take a fair amount of time) or you can try yourself with the aid of a thermometer. This will then at least give you an idea of the possible areas where energy can be saved.

It was found in tests on 17 houses that an improvement of up to 7 or 8% could be achieved by adjusting the tap setting — in one particular case the saving was as high as 24%! It might be a good idea to have a chat with your neighbour to see how your systems compare.

Be critical when extending the heating system. Don't be tempted to use cheap second-hand radiators. Let the company who installed your central heating advise you, since different standards are often applied. The addition of wrongly measured radiators and pipes could 'unbalance' your system!

The room thermostat

A separate article has been devoted to this aspect elsewhere in this issue, so we don't need to go into the reasons for using a thermostat again. What we didn't mention was the fact that it is possible to check whether or not the thermostat is working correctly with the aid of a minimum/maximum thermometer. This is a dual thermometer which records the highest and at the same time the lowest temperatures to have been measured. If, for instance, the thermostat is set to 20° and the thermometer indicates 18° to be the lowest and 22° to be the highest temperature, the thermostat will be incorrectly set. Ideally, the room temperature should be constant to within at least 1° and preferably 0.5°.

It is obvious that this kind of measurement should not be carried out with children playing nearby who leave doors open.

Of course, if the temperatures are automatically lowered at night, regulation has to be precisely controlled. The minimum/maximum thermometer will indicate whether the temperature has exceeded the preset value during 'warm-up'. If not, the setting can be altered until there is an overshoot. Then reduce the setting a little so that the temperature can no longer rise above the required value and the thermostat will be set at the optimum level.

Lowering temperatures at night

Unfortunately, this does not save as much energy as the advertisements would have us believe, but between 5 and 10% can be achieved. The best method is to adjust the thermostat by hand, although then of course this will have to be done systematically. Tests have shown that in this manner 25% more can be saved than when using an automatic timer. (Please note: not 25%, but 25% *more* than the original 10%, in other words, 12.5%).

For an automatic night reduction system all you need is a timer. The thermostat can quite easily be 'fooled' by incorporating a heating element, such as an ordinary resistor. At night this resistor, for instance a 4k7/¼ W type, will be connected across a 24 V supply by the timer and the air inside the thermostat will become a little warmer than the surrounding air. As a result, the temperature of the room will drop until the room temperature plus the heating caused by the resistor is equal to the preset value given on the thermostat. Thus, no mechanical controller (motors, couplings, gearboxes etc.) is required to adjust the thermostat setting by a few degrees.

With the aid of the minimum/maximum thermometer we mentioned before you can control the night temperature reduction. Lower than 5° will not give any more gain. For then so much extra heat will be required to warm up the floors, walls and ceilings, which cooled off during the night, that this will end up costing more energy than was saved during the reduction.

Investment

In a number of cases a little money will have to be spent before any appreciable amount of energy can be saved. This is particularly true of the automatic pump; however, its cost can be earned back within a few years. In addition,

about 20% of the warmth is lost 'up the chimney'. At least half of this can be won back with a so-called *economiser*. This useful device is placed behind the boiler to cool the fumes as much as possible. With a little bit of luck, these devices will be on the market before the year is out.

The economiser cools fumes from about 200° to almost the temperature of the return water of the central heating. This causes condensation: steam is produced and must be extracted. In addition, extra heat is released.

The fumes are now so 'cold' that the chimney or flue no longer draws them out. For this reason a ventilator will have to be installed to make sure the fumes are extracted. This involves an extensive (electronic) security system to check whether the ventilator is functioning as it should. The requirements which this system must meet are related to the danger of fire and explosions. Therefore, it is not advisable to start experimenting in this field, but rather to purchase a recommended type.

As far as fume valves are concerned, they can be dealt with quite briefly. They are all forbidden, for if one is used the same security system must be included as in the case of the economiser. In spite of the 20% which the fume valve would save, it just isn't worth it. In any case, the 20% refers to the static losses which the valve would reduce, not the gas consumption. The static losses amount to about 7% of the total gas consumption. Thus, the valve would cut this down to: 20% of 7% = 1.4%.

Static loss is the amount of energy lost up the chimney while the boiler is not burning. By using an economiser these static losses also disappear, so it is preferable to use an economiser. If the old boiler is due for replacement you can buy a new, economical version. If the entire system needs to be renewed, you might like to consider an *air heating* unit. This saves energy, as a lower air temperature manages to maintain the same degree of comfort.

Other methods to save energy include a rather curious one: if you like plants, don't be afraid to build a wide window sill in front of the windows. One that juts out by 20 cm saves around 14% more than none at all!

Insulation and ventilation

Subjects like double glazing, pipe insulation, filling up cracks etc. have received ample coverage so there is no need to go into these particular aspects again. What happens, however, if your house is well insulated but now feels damp and clammy and has an unpleasant smell? Of course, one way to get the ventilation going again is to re-open all the cracks, but it is far better to install an electric ventilator — like the ones included in newly built

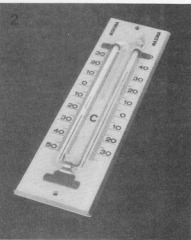
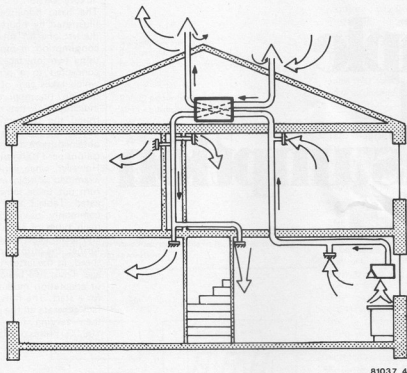

Photo 2. An example of a minimum/maximum thermometer.



81037 4

Figure 1. A ventilator makes sure that the air is constantly refreshed.

houses — to ensure a constant ventilation regardless of weather conditions (very windy, slight wind etc.).

The minimum prescribed ventilation is 225 m^3 of air per hour, allowing for less ventilation at night. The hot air is replaced by cold outside air which requires about 1000 m^3 of gas a year to heat it. Since ventilation is an absolute must, heat losses seem inevitable. Fortunately, a solution for this has been found in the form of a heat exchanger. This is a device which enables the hot air passing out to give its warmth to cold incoming air. Such devices manage to save at least 80%. With a ventilation loss of 800 m^3 a year and a total consumption of 3000 m^3 the new consumption figure using a heat exchanger will become 2360 m^3 , meaning that more than 20% of the total gas used is saved. Again, it does involve a slight increase in electricity consumption.

It should be possible to go one step further: by feeding the fumes from an ordinary central heating boiler through the heat exchanger. Quite a lot of electronics is involved to ensure the fumes are fully extracted as in the case of the economiser. The total performance will, however, be very good. As this development has not yet gained

official approval, it will take some time for it to be put into practice.

The future

It looks as if economy will prove to be the most reliable 'energy source' in the near future. Solar and wind energy systems are still in a primitive state of development. It may be possible (special kits are available) to cover half of the hot water requirements with solar energy, but it is still not economically viable compared to other fuel prices. This need not deter the enthusiastic constructor of course; after all, the sky's the limit!

Real saving will be possible with the aid of gas heat pumps. These extraordinary devices succeed in producing more heat than seems possible from the indications on the boiler. In other words, they exceed a performance of 100% (up to about 140%). This is because the pump can derive warmth from its surroundings, such as from the air or from water in the ground. Unfortunately, such devices are also very expensive and at the moment are reserved for large office buildings etc. It is estimated that the situation will

improve in the next few years however. Information on how to save energy in the home can be obtained from your local gas board, or from the firm who installed your central heating system.

simple fuel consumption meter

A meter indicating fuel consumption while the car is moving would appear to be a popular circuit.

The fuel consumption meter described in the April issue however suffered from a major disadvantage, unfortunately the transducers required could not be delivered. To remedy this the characteristics of all the transducers we could find were examined and on the basis of the results three 'universal adaptation modules' were developed. With the aid of these modules it should be possible to use virtually every transducer!

This article describes a simple version of a fuel consumption meter in addition to the modifications required to the 'luxury' version.

The basic principle is very simple, as illustrated by figure 1. Take two transducers: one for speed and one for fuel consumption in mpg (flow transducer) using two interface modules. These are connected to a printed circuit board which takes care of the necessary scale division (in mpg) and gives a digital indication of the result. By changing round the connections on the circuit board, the opposite result may also be obtained: gpm divided by mpg produces gallons per (100) miles.

However, when various transducers are examined a little more closely, things turn out to be somewhat more complicated. Table 1 lists a few of the most commonly used types. It shows two main types of speed transducers: pulse and tachogenerators. In the case of the former, the output frequency is equal to speed, in the latter, it is the output voltage. Thus, two basically different kinds of adaptation modules will be required for a start. The flow transducers will in fact generate all the pulses required, but then varying from about 32000 to 108,000 pulses per gallon.

What are the possibilities?

Thus, the fuel consumption meter could either be based on mpg or g/100 m. In addition there are two different kinds of speed transducers to be reckoned with: pulse and tachogenerators. This leads to four different block diagrams, as shown in figures 2 . . . 5.

Even so, the basic principle will remain the same, as can be seen from the right-hand half of the diagrams. To put it briefly: a digital frequency counter is really a divider as well! The counted pulses — and thus the figures in the display — are equal to the frequency at the clock input, and also to that of the latch/reset pulses. In other words, the indicated result is equal to the clock frequency divided by the latch/reset frequency.

The trick now is to make sure that for mpg the clock frequency is equal to miles per hour and that the latch/reset frequency is equal to gallons per hour. At the same time, the frequency ratio's must be such that the result of the division corresponds to the required display: mpg, with one figure behind the decimal point.

All this is achieved by using the correct modules. Figure 2 illustrates what happens when the speed transducer is a pulse generator. Module 1 is a presettable frequency multiplier and module 2 is a frequency divider. The two modules are preset to provide the correct ratio of clock to latch/reset frequency. Figure 3 on the

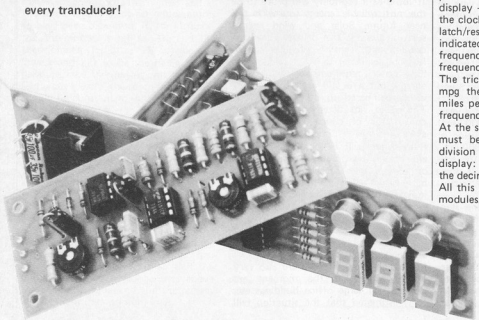

Table 1

Speed transducers	
Halda	4 pulses per rev
ITM	6 pulses per rev
tacho generators	direct voltage equal to speed
Flow transducers	
FioScan 201A	
203A	25600 pulses/litre of petrol
211A	26417 pulses/litre of diesel
213A	
FioScan 261PB-15	12680 pulses/litre of petrol
263PB-15	
FioScan 300-1	11386 pulses/litre LPG
KDM (opto)	9500 pulses/litre
KDM (inductive)	8500 pulses/litre

Table 1. A general survey of the flow and speed transducers available in the U.K. and of the number of pulse rate generated per gallon or per revolution.

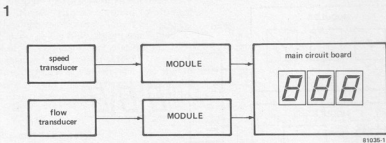

Figure 1. The block diagram of the fuel consumption meter.

2

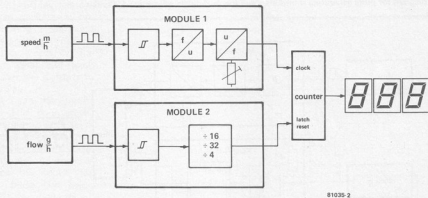

Figure 2. The block diagram of the pulse generating transducers and the read-out in miles per gallon.

other hand shows a speed transducer with a tachogenerator output. As a result a direct voltage equal to speed is produced. A module will therefore be required which converts this voltage into the (clock) frequency that is needed: a (presettable) voltage-to-frequency converter. This is module 3. The other two figures (4 and 5) are basically the same, with the only difference that the speed and fuel transducer have exchanged places.

The diagrams

The circuits themselves can be dealt with briefly. Their purpose has already been considered and the block diagram (figures 2 . . . 5) illustrate this.

Module 1 (figure 6)

This has the purpose of carrying out a presettable frequency multiplication to convert the pulses from the speed or flow transducer into the required clock frequency.

The module consists of a trigger circuit (IC1) which converts the input pulses into a symmetrical square wave and is followed by a frequency-to-voltage converter (IC2) and by a presettable voltage-to-frequency converter (IC3). Potentiometer P1 is used to adjust the trigger level. With respect to optoelectronic transducers the voltage at the wiper is set at 1 . . . 15 V and with induction types at a few hundred mV.

Module 2 (figure 7)

In addition to the presettable frequency

3

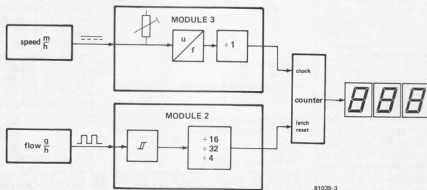

Figure 3. The block diagram showing how a tachometer is used and the read-out in miles per gallon.

4

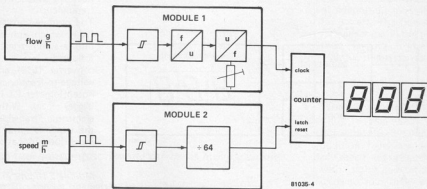

Figure 4. The block diagram for pulse generating transducers and the read-out in gallons per 100 miles.

5

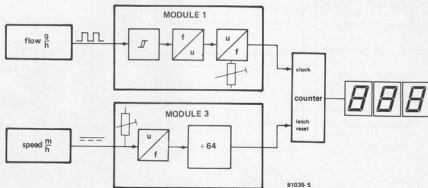

Figure 5. The block diagram showing how to use a tachometer and giving the readout in gallons per 100 miles.

6

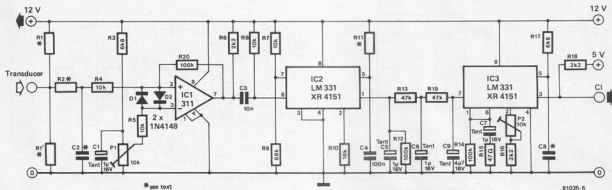

Figure 6. Module 1.

multiplier a programmable frequency divider will also be required to produce the latch/reset pulses. This is module 2. Since a single fully presettable converter will be enough for calibration, it is acceptable to use a divider (IC2) one of the outputs of which can be chosen with the aid of a wire link. Here too, the input pulses are initially 'cleaned up' by IC1.

Module 3 (figure 8)

Finally the voltage-to-frequency converter: module 3. Even less needs to be said about this. IC1 takes care of the conversion. In order to be able to produce either clock or latch/reset pulses as required (figure 2 or 4) a fixed divider has been included (IC2).

The main circuit board (figure 9)

Figure 9 gives the count/display section. The IC manufacturers have made life easy for us by including a complete counter with a seven-segment display decoder/driver. In other words, on one side there are clock, reset and latch pulses and on the other the outputs to the seven-segment displays.

Up to now we have been mentioning 'latch/reset' pulses. The counter IC prefers these to be split up into latch and reset pulses. This is no problem, as gates N1...N4 connected in series constitute a 'pulse delay'. As soon as a latch/reset reaches the input, N2 generates a short latch pulse. This makes sure the count in IC1 is 'remembered' and that it is on display. After a short delay (by means of N3) N4 will then generate the reset pulse which the counter in IC1 can reset to zero, ready for the following count cycle.

Construction

Building the circuit with the right

7

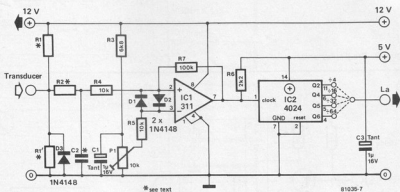

Figure 7. Module 2.

8

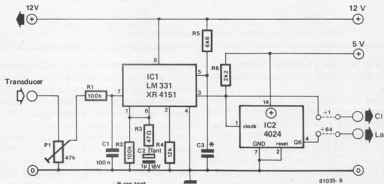

Figure 8. Module 3.

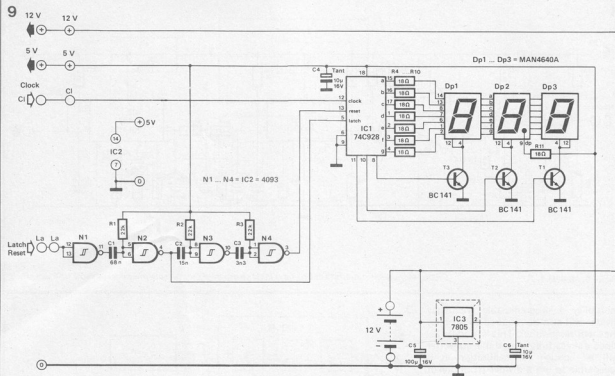

Figure 9. The display unit.

10

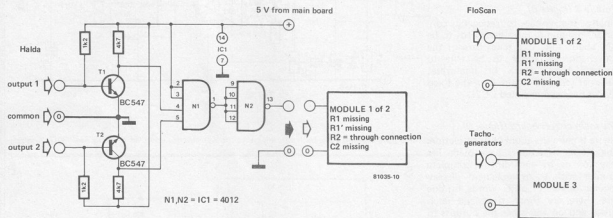

Figure 10. The adaptations required by various speed transducers.

modules and components is rather complicated, but the following survey will help.

1. How to choose the right flow and speed transducer

There is only one solution for this: go to your dealer and find out which transducers he can get hold of to mount in your car. The flow transducer will generally prove more easily obtainable than the speed transducer, but attention must be paid to see whether it is suitable for the fuel your car runs on: petrol, LPG or diesel.

It is advisable to select one of the transducers mentioned in this article. A car

accessories dealer with a large assortment may well have them in stock. On each module the adaptations and component values for all the above transducers are indicated. Other types may also be used, provided the calculations given further on in this article are taken into account.

Assuming a flow and speed type has been chosen, let us now see what the possibilities are.

2. What indication should be given?

Either the transducers can indicate miles per gallon (mpg), or gallons per 100 miles (1/100 miles). Once the choice has been made, figures 2 . . . 5 will show

the modules which are required. Two different types may be used for mpg and two for gallons per 100 miles, depending on the type of speed transducer selected. Check whether the transducer you bought is a pulse generator or a tachogenerator. Only one figure can meet the above requirements, so that it is not difficult to see which two modules are needed.

3. The values of the components which are transducer dependent.

These are provided in figures 10 and 11 and in tables 2 and 3. Figures 10 and 11 illustrate the components required by the speed and flow transducer respect-

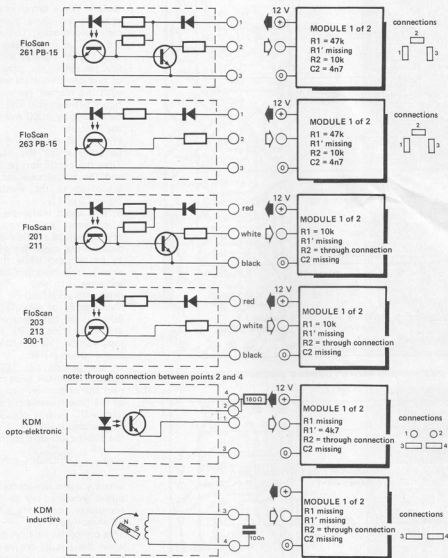

81035-11

Figure 11. The adaptations required by various flow transducers.

ively. Table 2 contains several component values for the gallons per 100 miles versions. It might be a good idea to make a note of all these values as you go along to avoid confusion later!

4. The construction of the modules

Now the two modules and the main circuit board can be built (after buying the components first of course). The components required may be found in the parts lists given.

The two modules are mounted at the rear of the main board. Make sure they are positioned correctly. This depends on the module chosen (2, 3, 4 or 5). It

shows which modules should be connected to the clock and reset/latch input of the main board. Next, the circuit will have to be calibrated. Don't connect the transducers yet!

5. Calibration

Calibration occurs in two steps, depending on the type of transducer chosen.

a. If a speed transducer is used which generates (opto-electronic or inductive) pulses, the calibration circuit shown in figure 12 must be utilised. This will generate 50 Hz pulses and should be connected to the inputs of *both* modules. After the supply voltage

has been connected, the display should show the result of the following formula:

$$\text{read out} = \frac{y}{1000 \cdot k \cdot X}$$

for miles per gallon and

$$\text{read out} = \frac{100000 \cdot k \cdot X}{y}$$

for gallons per 100 miles.

Where X stands for the number of pulses per speed transducer revolution and y for the number of pulses per litre that the flow transducer generates. The

Table 2

mpg

Flow	FloScan 261, 263, KDM 300-1	FloScan 201A, 203A, 211A, 213A
Speed		
Halda	module 2 wire link ÷ 16	module 2 wire link ÷ 32
	module 1 R11 = 22 k C8 = 15 n	module 1 R11 = 22 k C8 = 12 n
ITM	module 2 wire link ÷ 16	module 2 wire link ÷ 32
	module 1 R11 = 15 k C8 = 15 n	module 1 R11 = 15 k C8 = 12 n
Tacho- generator	module 2 wire link ÷ 16	module 2 wire link ÷ 32
	module 3 wire link ÷ 1 C3 = 4n7	module 3 wire link ÷ 1 C3 = 3n9

Table 2. The values of the components which are transducer dependent for the readout in miles per gallon.

Table 3

g/100m

Flow	FloScan 261, 263, KDM 300-1	FloScan 201A, 203A, 211A, 213A
Speed		
Halda	module 1 R11 = 82 k C8 = 12 n	module 1 R11 = 33 k C8 = 12 n
	module 2 wire link ÷ 64	module 2 wire link ÷ 64
ITM	module 1 R11 = 82 k C8 = 8n2	module 1 R11 = 33 k C8 = 8n2
	module 2 wire link ÷ 64	module 2 wire link ÷ 64
Tacho- generator	module 1 R11 = 82 k C8 = 12 n	module 1 R11 = 33 k C8 = 12 n
	module 3 wire link ÷ 64 C3 = 6n8	module 3 wire link ÷ 64 C3 = 6n8

Table 3. The values of the components which are transducer dependent for the read-out in gallons per 100 miles.

display will also show the result to one figure behind the decimal point. The number of pulses generated by the transducers is calculated by means of table 1. The k factor in the formula is a constant which is mentioned on the car's speedometer. This will be between 0.6 and 1.6 or between 600 and 1600. The former relates to the number of revs per meter, the latter to the number of revs per mile. Here we are concerned with the number per mile, so that the figure between 600 and 1600 must first be divided by 1000 and then be used in the formula.

With P2 of module 1 the read out can be adjusted to the value calculated. Then the circuit can be fitted in the car and the transducers can be connected according to the illustrations (either figure 10 or 11).

b. If a speed transducer is used which generates a DC voltage level, calibration will be a little more complicated because the speed transducer will have to be adjusted while the car is being driven. It is therefore advisable to take someone with you . . . unless you can drive with your feet!

Calibrate P1 of module 3 at a speed of 50 miles per hour to a voltage of 0.5 V at the junction of P1 and R1. In the mpg version this will complete the fuel consumption meter.

In the gallons per 100 miles version module 1 still has to be calibrated. Connect the calibration circuit to the input of the flow transducer module and connect a DC voltage of 1 V to the input of the speed module. The read out on the display will then be the result of:

$$\text{read out} = \frac{180000}{y}$$

where y again represents the number of pulses generated per gallon by the flow transducer used. This value is set with P2 of module 1.

This completes calibration here too and again the circuit can be built into the car and the transducers connected according to figures 10 and 11. Check whether P1 in module 1 is still set to the correct value, just to be on the safe side. (See the corresponding diagram.) Finally a word about the supply. The 12 V for the circuit must not include

12

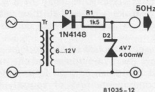

Figure 12. The calibration circuit used to set up the meter.

Parts list module 1 (figure 6)

Resistors:

R1, R1', R2, R11 = see text
 R3 = 6k8
 R4, R5, R7, R8 = 10 k
 R6, R16, R18 = 2k2
 R9, R17 = 68 k
 R10 = 18 k
 R12, R14, R20 = 100 k
 R13, R19 = 47 k
 R15 = 47 Ω
 P1, P2 = 10 k preset

Capacitors:

C1, C5, C6, C7 = 1 μ /16 V tantalum
 C2, C8 = see text
 C3 = 10 n
 C4 = 100 n
 C9 = 4 μ /16 V tantalum

Semiconductors:

IC1 = 311
 IC2, IC3 = LM 331, XR 4151
 D1, D2 = 1N4148

13a

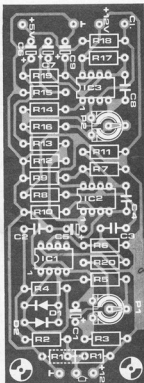
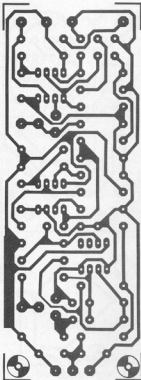

Parts list module 2 (figure 7)

Resistors:

R1, R1', R2 = see text
 R3 = 6k8
 R4, R5 = 10 k
 R6 = 2k2
 R7 = 100 k
 P1 = 10 k preset

Capacitors:

C1, C3 = 1 μ /16 V tantalum
 C2 = see text

Semiconductors:

IC1 = 311
 IC2 = 4024
 D1... D3 = 1N4148

13b

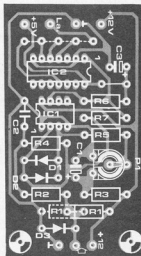
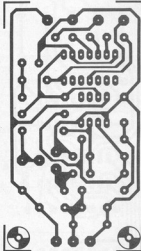

any interfering pulses from the car electrical system and this can be avoided by using a noise filter, like the ones used for car radio's. That covers the use of all the transducers described here.

This fuel consumption meter is really universal. It can be adapted and calibrated for almost any transducer, provided enough information is available.

The luxury consumption meter

The meter we described in the April issue can be switched to four measuring ranges: gallons per 100 miles, gallons

per hour, miles per gallon and rev count. This if of course ideal and not surprisingly many readers are still searching for the transducers required.

The same solution which was provided for the simple version can now also be applied here using the adaptation modules. Two input signals are required: a pulse signal equal to the fuel flow (about 3400 pulses per gallon) and a DC voltage level equal to the speed (about 5 V at 60 miles per hour). Since the existing circuit already offers ample calibration range, the output signal levels of the modules need only be roughly estimated.

How to use the flow sensor

Table 1 provides details of a number of different types of flow sensors. It can be seen that the conversion ratio's can vary between 32,000 and 108,000 pulses per gallon. Some sensor may show even wider tolerances. In any case the frequency of all these sensors will have to be reduced with the aid of an interface circuit as described with respect to the simple meter.

How to adapt the speed transducer

Since the luxury circuit is meant for a

Parts list module 3 (figure 8)

Resistors:

R1,R2 = 100 k
 R3 = 47 Ω
 R4 = 12 k
 R5 = 6k8
 R6 = 2k2
 P1 = 47 k preset

Capacitors:

C1 = 100 n
 C2 = 1 μ /16 V tantalum
 C3 = see text

Semiconductors:

IC1 = LM 331, XR4151
 IC2 = 4024

13c

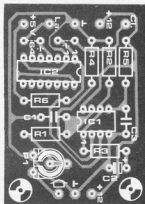
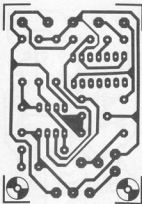

Parts list main board (figure 9)

Resistors:

R1,R2,R3 = 22 k
 R4 ... R11 = 18 Ω

Capacitors:

C1 = 68 n
 C2 = 15 n
 C3 = 3n3
 C4,C6 = 10 μ /16 V tantalum
 C5 = 100 μ /16 V

Semiconductors:

IC1 = 74C928
 IC2 = 4093
 IC3 = 7805
 T1,T2,T3 = BC 141
 Dp1 ... Dp3 = MAN 4640A

Miscellaneous:

heatsink for IC3

13d

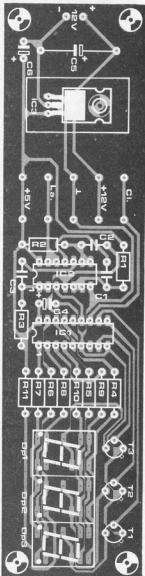
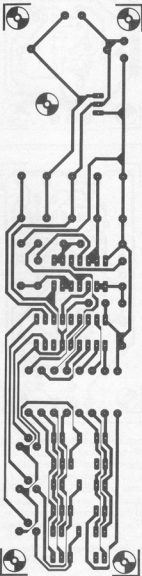

tacho generator, this kind of sensor can be connected directly. Pulse generator transducers (and there are any more of these available) require the frequency to voltage converter in first half of module 1 (up to and including junction R13/C6). **K**

Figure 13. The component overlay of the circuit boards.

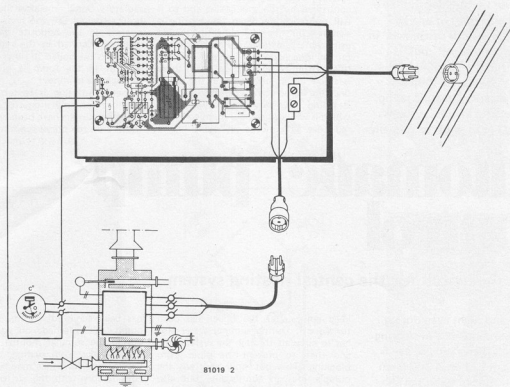

Figure 2. The central heating system is connected to the mains via the automatic pump control.

an auxiliary device may only be added if it is connected to mains and to the wires leading from the room thermostat. Once it is connected to the gas system, the device must also be approved by the Gas Board. We mention this fact, because there are many automatic pump controls in existence which do *not* meet these standards and which could be dangerous! With regard to electrical safety, according to official requirements, there should be at least 8 mm space on a printed circuit board between the 220 V and the 24 V circuits. Furthermore, the optocoupler should have an insulation voltage of 4 kV. The system should also be electrically 'fail-safe', that is, the boiler should be unable to burn if the pump does not go into operation due to a fault in the circuit. This has been solved here, because when the pump receives no voltage, the gas valve will automatically be closed.

Another aspect to take into consideration is whether the boiler is in fact suitable for such a device. If the boiler is not connected to the mains via a plug and socket, you can be pretty sure it is not suitable. If in doubt, consult the local Gas Board.

The circuit

Figure 1 shows the circuit diagram of the automatic pump control. The circuit's input terminals are mounted in parallel to the switch in the room thermostat. If the thermostat switch is open, there is a difference in voltage between the two input terminals and the LED lights. When the thermostat switch is closed, this will of course not be the case. The LED forms the input of an opto-coupler which has a very high isolation voltage (4 kV).

The output of the opto-coupler is a photo transistor. As soon as the LED lights, this transistor conducts so that the reset input of IC2 will be connected to 0 V. When the room is not at the correct temperature, the thermostat switch will be closed and the LED will not light. The transistor will then not conduct either, so that the reset input of IC2 will be high. In that case, all the outputs of the IC will be low, T1 will close, D9 will not light and the relay will be at rest. Since the pump is connected to the supply voltage via normally closed contacts of the relay, it will be activated. As soon as the right

temperature is reached, the LED will go out and the reset line of IC2 will become low. Then the outputs $Q_0 \dots Q_{10}$ will become high in sequence with intervals preset by the RC time constant of R3, R4, C2 and C3. Outputs $Q_0 \dots Q_3$ are not used, so that, for the period up to Q_4 going high, nothing will happen. The $Q_4 \dots Q_{10}$ outputs will still be low, T1 will remain closed and the relay will remain closed allowing the pump to continue to operate. It is not until Q_4 becomes high, which is after about 15 minutes, that T1 will conduct causing the relay to be activated and the pump to be switched off. IC2 is a binary counter and thus the 15 minutes are a result of counting to 8 in binary to the clock frequency. (Eight times 1 minute 53 seconds is about a quarter of an hour.) Once Q_4 has become high and the pump is switched off, the IC continues to count. It carries on until Q_{10} after which all the outputs will automatically become low again. One complete counting cycle takes 32 hours. The IC will then start a new counting cycle, but because $Q_0 \dots Q_3$ are not being used, the pump will operate for another 15 minutes. During the summer

3

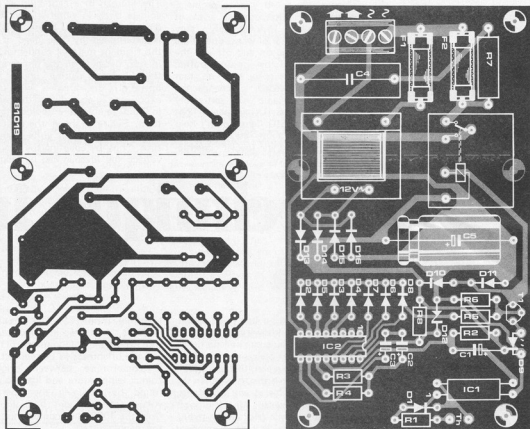

Figure 3. The track and component layout of the printed circuit board.

Part List

Resistors:

R1 = 3k9
 R2 = 1 M
 R3 = 10 M
 R4 = 4M7
 R5 = 22 k
 R6 = 10 k
 R7 = 220 Ω /1 W
 R8 = 1 k

Capacitors:

C1 = 1 μ /25 V
 C2, C3 = 15 μ /25 V
 C4 = 0,33 μ /630 V
 C5 = 470 μ /25 V

Semiconductors:

D1 ... D8, D10, D11 = DUS
 D9 = LED
 D12 = zener diode 15 V/400 mW
 D13 ... D16 = 1N4001
 IC1 = OPI 1264
 IC2 = 4060
 T1 = BC 517

Miscellaneous:

transformer secondary
 12 V/100 mA
 relay 12 V 1 normally closed
 printed circuit fuse holder
 fuse 63 mA

the pump will operate for a quarter of an hour after every 32 hours, but in the winter the room will of course cool off long before 32 hours have passed and so the thermostat switch will close again before the entire counting cycle can be completed. In that case, the LED of the opto-coupler will have gone out again. The reset line of IC2 will then be high so that it will stop counting at the same time all the outputs of the IC will become low and the pump will go into operation again.

The construction

Figure 3 shows the component layout for the printed circuit board for the simple central heating automatic pump control. The complete circuit including the relay, can be mounted on the board (the distances between the tracks meet safety requirements). If another supply is available, the part of the printed circuit board incorporating the supply circuit will not be required. That part of the board can then be sawn off.

The LED (D9) indicates whether or not the pump is in operation and so should be mounted where it can be clearly seen.

When the light is out, the pump will be working, when it is on, it will be inactive. Of course, the LED will only indicate whether or not the relay is activated and so will not show up any mechanical defect the pump might have. For the relay it is best to use a 12 V type, which can switch at least 1 A. Figure 2 illustrates how the circuit is connected to the central heating system.

M

Between 20,000 and 100,000 operational hours using "ordinary" light bulbs.

long-life technique in light bulbs

The standard household light bulbs currently on the market are designed to last about 1000 hours. Where bulb failure leads to security risks or high maintenance costs, it would be an advantage if their lifespan could be prolonged. How this can be done without cutting out too much light will be seen in the present article.

When the famous Berlin clock was put into operation its inventor Dieter Binniger was faced with a problem. The time indication used an array of ordinary bulbs. Unfortunately, they only lasted a matter of weeks due to the constant switching on and off and the vibrations caused by passing traffic. Since the clock is so high up that scaffolding is needed to change the bulbs, this became an extremely expensive business. Using special light bulbs, so-called SIG lights, didn't help matters, as their failure rate was still too high in spite of their special construction.

Thus, a new solution had to be found. It is common knowledge that the lifespan of a light bulb can be lengthened by reducing the operational voltage. This however also means that the brightness will be less. In order to lengthen the lifespan without losing any brightness, the clock's designer Mr. Binniger resorted to a simple trick: when reducing the operational voltage in standard light bulbs he at the same time used a higher wattage thereby achieving the same degree of brightness as before. The bulbs now only have to be changed once a year and thus cutting down maintenance costs considerably.

Experimenting with light bulbs

The lifespan of a light bulb at normal voltage levels in vibration-free surroundings is about 1000 hours. This period is determined by the speed at which the filament material condenses, which in turn depends on the temperature of the filament. During under voltage operation the lifespan will increase exponentially according to the reduction in bulb temperature (colour temperature). Figure 1 shows the relationship between operational voltage and lifespan. Thus, by adapting the operational voltage the lifespan can be lengthened

infinitely. It must be taken into account however that a drop in colour temperature causes the colour spectrum to shift and the brightness to be reduced. Thus, a compromise between brightness, colour temperature and lifespan can be found by changing the operational voltage of the light bulb (deviating from the 1000 hour compromise set by the manufacturer).

Figure 2 gives a diagram of the colour temperature values pertaining to 40, 75, 100 and 150 watt/220-230 V household bulbs in relation to the operational current. These are usually designed for a lifespan of 1000 hours at 227 volts

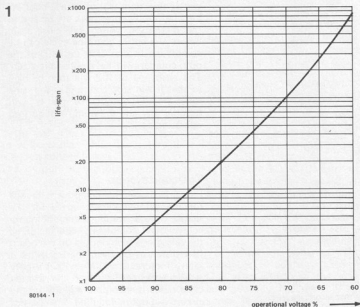

Figure 1. When the operational voltage of a light bulb is reduced the lifespan will be increased exponentially.

operational voltage. The nominal operational values of light bulbs form a 1000 h curve (to the far right) in the diagram. It can be seen that colour temperature increases with bulb power rating at a given nominal voltage.

It can also be seen for instance that if a 75 W light bulb were to have its colour temperature reduced to that of a 40 W light bulb (about 2500°K) an average lifespan of more than 10,000 hours can be achieved.

Light bulbs for advertising purposes, signals and effects usually require but one colour. Traffic lights for instance use a filter effect with red, yellow and green diffusing screens. The colour of the red and yellow light would therefore not really change even if the colour temperature of the light bulbs were to drop to 2000 K. The green light will start to turn slightly brown when the filament temperature drops below 2250 K. Here the colour temperature can therefore be reduced much more than in light bulbs used for lighting purposes such as street lamps, etc. As shown in figure 2, when the filament temperature of a 150 W all purpose lamp is reduced to 2350 K, an average lifespan of a million hours will be the result!

Applications

Signal and traffic light installations would definitely benefit from this

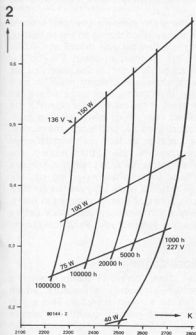

Figure 2. The diagram shows the relationship between the colour temperature and the operational current for four all purpose light bulbs with different performances (horizontal curves). The vertical lifespan curves connect the operational points of an identical life expectation. The 1000 h curve (to the far right) is valid for a nominal 227 V operational voltage rate.

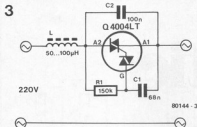

Figure 3. The circuit diagram of the 'long-life unit'. It consists of a phase cutoff control with a predetermined cutoff angle re reduce the operational voltage of light bulbs. With this circuit light bulbs can be operated up to 400 watts total power.

idea. Cities like London have to spend millions of pounds on traffic light maintenance. Thus, not only could costs be cut, but the systems would be more reliable as well and fewer accidents would be caused by light failure. Generally speaking, the long-life technique described is an advantage wherever special lights are being used and wherever changing bulbs is a difficult or costly operation. It might also be a good idea in vehicles, brake lights and indicators, for instance. As in the case of traffic lights, the colour temperature may be reduced considerably due to the coloured glass coverings.

The operational voltage in vehicles can be reduced by pulse width modulation. Instead of the commonly used 12 V bulbs, it would be better to take 16 V or 18 V bulbs. Unfortunately, such bulbs are not yet available for motorised vehicles.

How to put the idea into practice?

Photo 1 shows a switching unit built by Pieter Binnering to reduce the operational voltage of 220 V all-purpose light bulbs. The circuit is shown in figure 3. It consists of a standard light dimmer circuit with a diac/triac the phase cutoff angle of which is preset by resistor R1 and capacitor C1. Naturally, a light dimmer may also be used. If resistor R1 in figure 3 is replaced by a trimming potentiometer, the user can establish the compromise (operating point) between the colour temperature (brightness) and the bulb's lifespan.

The unit shown in photo 1 was used to operate a new 100 W light bulb and compared to a new 60 W version (same brand). It was tried out on a number of people who were unable to tell the difference in brightness between them. Even the slight shift in phase spectrum of the dimmed 100 W lamp escaped all notice. More than half of the observers even thought the 100 W bulb to be slightly brighter than the 60 W operated on full voltage.

The long-life technique for light bulbs was patented by Binnering Berlin Uhr GmbH in West Germany under nos. P 30 01 755.1 and P 2921 864.2.

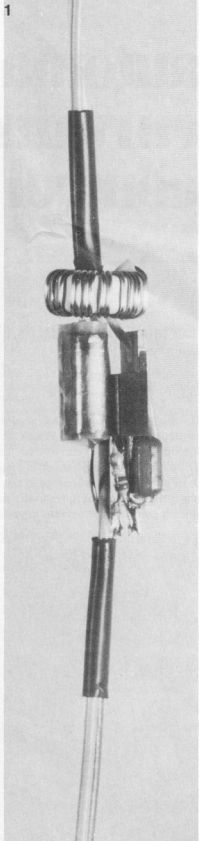
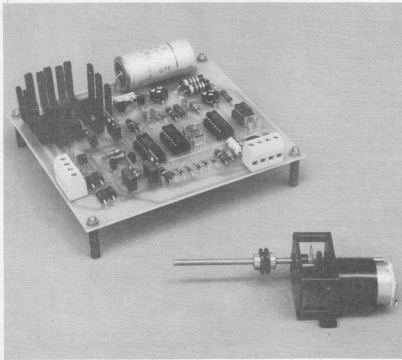

Photo 1. A prototype switching unit corresponding to the circuit in figure 3.

automatic curtain control

'curtains' for draughts

Quite a lot of energy can be saved if the curtains are drawn as soon as the light begins to fade. This is something which can quite easily be forgotten and so if it can be done automatically, so much the better. The circuit described here does the job electronically and although it costs a little electrical energy, it has many advantages, one of them being that it keeps burglars in the dark when you're away on holiday, since it continues to operate in your absence.



Last April the Organisation for Applied Scientific Research in The Netherlands (TNO) published a report on the energy-saving possibilities provided by curtains, especially with regard to their use in the home and in the office. The object of the exercise was to see how much heat dissipation through the outside walls is affected by curtains, window sills, the position of the radiators, etc. Research was carried out in a special climatized room in the Institute of Health and Environment and the report provides detailed results of the (many) measurements taken.

Curtains and window sills were found to have considerable influence on the loss of warmth. Figure 1 gives a few results of the research. The average situation is that where the radiator is placed under a single glazed window with a sill. The energy consumption of the central heating was preset to a fixed value (0%). When the sill is removed (see figure 1a) the heat dissipation increases at once by 13%. Thus, the window sill appears to deflect the hot air (into the room) instead of letting the cold glass absorb it. If the radiator is placed a little further away from the window, enabling curtains to hang (down to the floor) between the wall and the radiator, dissipation is seen to drop by 21%. In the fourth situation (figure 1d) the radiator is placed beneath the window sill and the curtains and net curtains are hanging from the ceiling to the window sill (so they're relatively short). Then, 25% less heat is lost.

In the given example the total amount of money saved during an entire heating season when gas was priced at £ 0.08p per m³ amounts to about £ 0.75p per m² of house front. In the course of the years, therefore, curtains prove to be a good investment. Even more money can be saved if the curtains are closed at the correct time, so curtains that shut automatically are also well worth the money. As a matter of fact, such a mechanism can save you more than money, for when you're away on holiday, burglars will be fooled into presuming you are still at home when they see the curtains open during the day and closed at night. They will therefore think twice before selecting your house as a possible target.

Block diagram

To close curtains automatically a mechanical system is required, which relies on an electric motor. This article describes a control circuit for such a motor, but the mechanical section will differ from case to case and therefore design is best left to the individual. One motor is enough to close two curtains of the same width if they are activated/driven simultaneously with the aid of small chains. The best time to close the curtains is at dusk, for in winter the temperature drops as soon as it gets dark. In any case the lights will already be on, so that no energy will be lost by

1

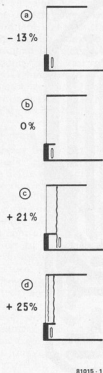

Figure 1. How to save heat by using curtains and window sills. Figure 1b shows the normal situation where no heat is saved.

2

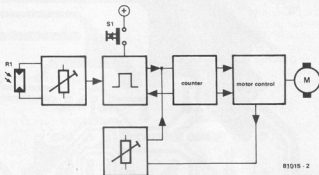

Figure 2. The block diagram of the automatic curtain control.

shutting out the dim half-light. Thus, an essential requirement is a switch that is sensitive to light. Of course, it should also be possible to operate the system manually.

The sensitivity of the system must be adjustable and the motor must stop automatically whenever the curtains are fully open or closed. This can be detected by micro-switches mounted on the curtain rails, but there is another method. When one of the extreme positions is reached the motor becomes overloaded. The curtains stop moving and the motor stops running. This

causes the motor's back-emf (electro motive force) to drop and the current through the motor to increase. The increase in current can be detected and an adequate stop mechanism can be based on it.

The block diagram of the automatic curtain control is shown in figure 2. The light sensitive switch with an adjustable threshold is situated in the square to the far left. The circuit generates a pulse whenever the switching time is reached. This output pulse is fed to a logic circuit operating a counter. This counter takes care of the actual motor control and is

3

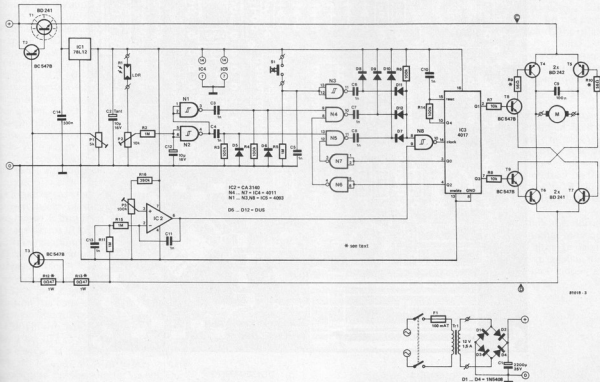

Figure 3. The circuit diagram of the automatic curtain control.

3

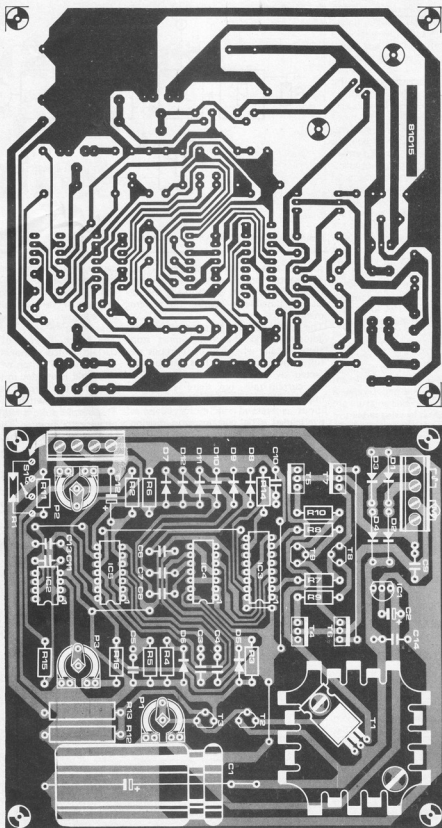

Figure 4. The printed circuit board and component overlay for the automatic curtain control.

also connected to a detector. The detector establishes whether there is too much current flowing through the motor (the curtains are then in an extreme position) and then transmits a pulse to the counter. The counter then stops controlling the motor. In actual fact the counter acts like a memory in the circuit. It remembers in which direction the motor last turned and ensures that it turns in the opposite direction at the following start instruction.

Circuit diagram

Figure 3 shows the circuit diagram of the automatic curtain control. It is based on a motor which turns according to the direction of the current flowing through it, in other words, it is a DC motor. There are several suitable motors available on the market.

The motor control consists of a total of six transistors of which three conduct depending on the direction in which the motor is to turn. Transistors T8, T4 and T7 conduct when the motor turns anti-clockwise (left) and T9, T5 and T6 conduct in the other direction. The two output stages are controlled by IC3 (a 4017 counter). This counter receives clock pulses from either the switching circuit or from a pushbutton. These pulses are gated by N4 and N5 before being fed to the counter. These gates are in turn controlled by the counter itself via N6 and N7.

The counter can only count to four, for the Q4 output is connected to the reset input. Whenever Q4 goes high, the IC receives a reset pulse so that Q0 goes high and all the other outputs go low.

Even when the supply voltage is connected to the circuit for the first time, the reset is activated automatically (via the network C10/R14). This causes one of the inputs of N5 to go low via N7, preventing the first clock pulse from reaching IC3 through N5. The first clock pulse to be received by the counter will be generated by the light sensitive circuit via N1, N2, N4 and N8 or via the pushbutton, N3 and N8. The clock pulse causes Q0 to go low and Q1 to go high. As a result, transistors T8, T4 and T7 start to conduct and the motor starts to turn anti-clockwise. The curtains close until their limit is reached. Resistor R12 and transistor T3 ensure that the current never becomes excessive while the motor is turning. This is because the voltage across R12 determines whether T3 is conducting. If so, T1 and T2 turn off and the motor no longer receives supply voltage.

The motor current also passes through R13. If the curtain is in the extreme position the back-emf of the motor will decrease and the current through it (and R13) will increase. This voltage is monitored by IC2 to see whether it exceeds a preset value (adjustable by means of P3). If it does, IC2 generates a new clock pulse for the counter via N8. Output Q1 then goes low again and Q2 goes high. One of the inputs to N4 is then

Parts list

Resistors:

R1 = LDR 1 M
R2, R5, R11, R15 = 1 M
R3, R4, R6, R14 = 100 k
R7, R8 = 10 k
R9, R10 = 56 Ω*
R12, R13 = 0Ω47/1 W*
R16 = 390 k
P1 = 5 k preset
P2 = 10 k preset
P3 = 100 k preset

Capacitors:

C1 = 2200 μ/25 V
C2 = 10 μ/16 V
C3 ... C8, C10, C11, C13 = 1 n
C9 = 100 n
C14 = 330 n

Semiconductors:

T1, T6, T7 = BD 241
T2, T3, T8, T9 = BC 547B
T4, T5 = BD 242
D1 ... D4 = 1N5408, BY 133
D5 ... D12 = DUS
IC1 = 78L12
IC2 = CA 3140
IC3 = 4017
IC4 = 4011
IC5 = 4093

Miscellaneous:

S1 = pushbutton
Tr = 12 V/1.5 A transformer
M = motor 3 ... 4 V
Z1 = 100 mA fuse
board fuseholder
heatsink for T1

* see text

taken low via N6 so that the former gate is inhibited.

When it starts to get light again a new clock pulse is generated which reaches the counter via N5 and N8. The Q2 output of the counter then goes low and Q3 goes high. Transistors T9, T6 and T5 then conduct and the motor starts turning in a clockwise direction. When the curtains are completely open IC2 will generate another pulse. Then Q4 goes high and the counter is reset.

The circuit around N1, N2, N4 and N5 is designed so that a positive-going clock pulse is generated at every change in light intensity (from dark to light and vice versa). If the pushbutton is operated a positive pulse will also reach the clock input of IC3 via N3. The pushbutton allows the curtains to be brought into any (mid-)position as required. Press once to start and again to stop.

Construction

It is best to use a DC motor with a (built-in) gearbox or similar reduction

mechanism. Such motors are available from most model shops. The prototype is pictured in the accompanying photograph. The motor's voltage must be between 3 and 4 volts. The current passing through the motor will be about 800 mA during normal operation. The values of R9 and R10 can be altered to suit different types of motors. The following formula can be used to calculate their values:

$$\frac{U_{CD}}{R9 \text{ or } R10} = \pm 80 \text{ mA.}$$

When the motor voltage is 3 V, U_{CD} must be about 5 V and the value of R9 and R10 must be about 56 Ω.

The current threshold should be set to about 1.2 A. The limitation does not operate when the motor is running, but when the motor stops turning, after reaching the extreme position, the current will exceed 1.2 A.

The current threshold is determined by the value of R12. As soon as the current exceeds 1.2 A, T3 will conduct and T1 and T2 will turn off. The voltage across R12 must therefore become greater than 0.6 V. If the value of 1.2 A is maintained R12 will have to be about 0.47 Ω. The voltage across R12 + R13 is monitored by IC2 to determine whether or not the curtains have got as far as they can go. Usually, R13 will have the same value as R12. The adjustment range of P3 is large enough to preset the correct current threshold.

The printed circuit board designed for the automatic curtain control is shown in two perspectives in figure 4. Transistor T1 must be provided with a sufficiently large heatsink. Room has been reserved for this on the board. The other transistors do not require heatsinks.

Of course, the finished curtain control will look different for each individual system. It is up to the constructor to find the easiest solution to complete the mechanical section.

To achieve a good switching sensitivity, the LDR must be mounted in such a place that the light intensity outside the house is measured. The site must be chosen so that street lights and passing cars, for instance, have no effect on the circuit. And, of course, the LDR must not be placed in the artificial light of the living room.

For those of you who think that this is all rather complicated another solution is to place a time switch either in parallel to or instead of S1 to enable the curtains to be opened and closed at pre-determined times. ■

Literature:

Documentation sheet 106 by TNO, 'Saving energy with curtains'.

fridge alarm

'freeze' energy

Most modern fridges are made up of thick layers of insulating material to reduce energy consumption to a minimum. Even so, however well the fridge is insulated, if the door is opened frequently or left open for longer than necessary no amount of insulation will keep costs down.

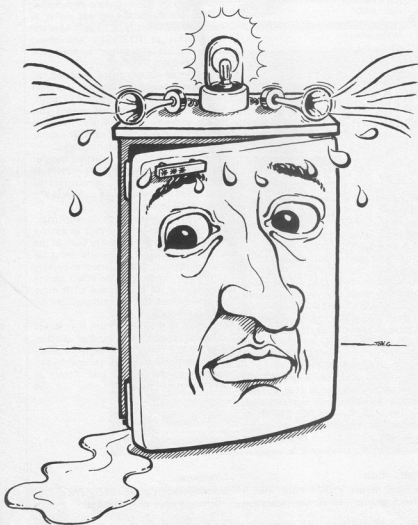

It is easy to see that however careful the family is when going to the fridge, the chances of the door being left ajar, for quite lengthy periods, are fairly high. We are informed, from a reliable 'source', that on occasion things can become somewhat hectic during cooking and checking to see whether the fridge is closed would not be on the list of high priorities. Understandable, but expensive all the same. Thus, some kind of warning device to attract your attention to the open fridge door would be a great help.

The alarm circuit here is activated by the fridge interior light, that is, whenever the door is opened. The alarm will remain silent for a preset period of time after which it will emit a high pitched tone every two seconds.

Block diagram

The block diagram for the fridge alarm is shown in figure 1. The simplest method of triggering the alarm is to measure the light level inside the fridge, since opening the door will turn the light on. A light dependent resistor (LDR) is used for this purpose in the Elektor fridge alarm since they are fairly cheap and readily available. The LDR switches the power to the alarm circuit by means of a series pass transistor.

The first part of the circuit is a timer which has an adjustable delay period of between 5 and 30 seconds. Once the preset time has elapsed, a low frequency oscillator will start to generate a short pulse every two seconds. This in turn controls a second oscillator so that a tone is emitted by the loud-speaker every two seconds. The pitch of the second oscillator can also be varied.

Circuit

The circuit diagram of the fridge alarm is shown in figure 2. Very few components are required and it is constructed around a single 4093 IC. The power supply is provided by a 9V battery. The series transistor T1 is connected in the positive supply line. The base of this transistor is connected to the voltage divider consisting of R1, R2 and the LDR (R3). The base drive voltage therefore depends on how much light falls on the LDR. The variation in resistance between 'dark' and 'light' is sufficient to make the transistor conduct.

As soon as T1 starts to conduct the rest of the circuit receives power and C1 charges up via R4 and P1. This, of course, takes a certain period of time which is adjustable by means of P1. When C1 is sufficiently charged, pin 1 of N1 will be 'high' and the oscillator constructed around N1 will start up. The output of N1 will then go low for a period of time determined by the values of R6 and C2 and will go high

for a period determined by the values of R5 and C2.

With the values shown, the output will be high for about 2 seconds and low for about 0.3 seconds. This signal is then inverted by N2 to provide a trigger pulse for the second oscillator. This second oscillator is constructed around N3 and its frequency may be varied between 3...10 kHz by means of P2. The output signal (or 'burst' signal) from N3 is inverted by N4 before being fed to a darlington transistor. This transistor provides sufficient signal amplification for the loudspeaker.

A special piezo 'buzzer' (TOKO) could also be used instead of the loudspeaker and output transistor. In this case the components R8, R9, T2 and the speaker may be omitted.

Construction

Construction of the circuit should not pose any problems, especially if the printed circuit board shown in figure 3 is used. The completed board should be mounted in a plastic case as the whole unit must be placed inside the fridge. One battery should last for one or two years, so there is no need to make any complicated mains power supply connections.

It is advisable to mount the LDR case.

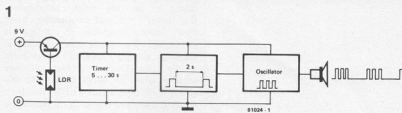

Figure 1. The block diagram of the fridge alarm.

2

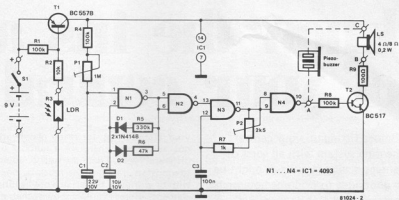

Figure 2. The circuit diagram of the fridge alarm. The 'delay' time can be altered with P1 and the tone frequency can be adjusted with P2. If a piezo buzzer is used then P2 will have to be adjusted to give its resonant frequency (about 4.6 kHz). The buzzer will then produce the ideal volume.

Parts list

Resistors:

- R1, R4, R8* = 100 k
- R2 = 10 k
- R3 = LDR
- R5 = 330 k
- R6 = 47 k
- R7 = 1 k
- R9* = 100 Ω
- P1 = 1 M preset potentiometer
- P2 = 2k5 preset potentiometer

Capacitors:

- C1 = 22 μ /10 V
- C2 = 10 μ /10 V
- C3 = 100 n

Semiconductors:

- T1 = BC 557B
- T2* = BC 517
- D1, D2 = DUS
- IC1 = 4093

Miscellaneous:

- LS = loudspeaker 8 Ω /0.2 W
- or TOKO buzzer type PB 2720

* see text

3

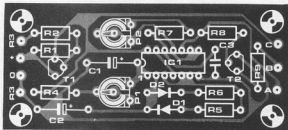
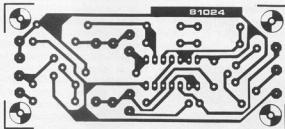

Figure 3. Component overlay and track pattern of the printed circuit board for the fridge alarm.

Nowadays where the reigning motto seems to be 'the more complicated, the better' and just about everything from sewing machines to cameras is controlled by electronics, a central heating system appears delightfully simple in construction. In fact, you may wonder what on earth there is to say about it. It consists of a boiler in which water is heated, a pump to transport the hot water to a number of radiators throughout the house which in turn heat up the air in the rooms and finally a thermostat to switch the boiler on and off.

That last component, the thermostat, however is something we wish to draw

the room temperature will rise higher. As far as the switching on point is concerned, the opposite obviously happens. This delay causes unnecessarily large fluctuations in the room temperature, which is illustrated by the curve in the drawing of figure 1.

The thermostat here is preset at 20°C. The 'on' and 'off' switching points are at 19.5 and 20.5°C respectively. If the heating is switched off at a room temperature of 20.5°C, there is still enough hot water in the system to allow the temperature to rise to about 22°C before starting to drop. When the heating is switched on, the opposite occurs. In other words the room

know the ins and outs of your central heating

Before fitting up your central heating system with all sorts of energy saving circuits, it might be a good idea to find out how such a system works. It happens quite often that a considerable amount of energy can be saved by conventional means. To start with, the heating system should satisfy particular needs and its individual parts should be well adjusted to each other. This may seem a platitude on the face of it, but in practice things have been found to turn out quite differently.

your attention to, for many people are not aware that there are a number of different types. There are wall or room thermostats, radiator thermostats, ones with or without a presettable pre-heating element. Research has shown that in many cases the thermostat used either just does not go with the heating system or has been incorrectly preset.

Let us take a closer look at the various types.

Room thermostats

Wall or room thermostats are either two of three wire versions. We'll come back to the difference between them later. The two wire version is by far the most common.

Both types contain a temperature sensor and a switch. For the sensor a bi-metallic strip is usually used and the switching function is generally provided by a mercury switch. The thermostat's case is made in such a way that the surrounding air can easily pass through. If the room temperature drops below a value lower than the preset level, the switch will close and turn the boiler on. When the temperature rises above the set level the heating is switched off again.

In practice, the necessary difference in temperature between the 'on' and 'off' point (1 or 2 degrees) is too great.

The moment the heating is switched off, a fair amount of heat in the system is 'under way' so that

temperature will vary between 18°C and 22°C. Very inconvenient and a waste of energy.

To bring the 'on' and 'off' points closer to each other, an 'anticipation' device is incorporated in the bi-metallic strip. As a result, the boiler is switched off sooner than the switching-off temperature is reached. What we now have is a kind of thermostat 'with initiative' which calculates the delay effect beforehand. The curve in figure 1 describes the reduction in room temperature fluctuations when a heat 'anticipation' device is used. Whereas the 'ordinary' thermostat switches on and off twice per hour, now it will switch six times. As a result the room temperature remains fairly constant and nearer the preset level.

As previously mentioned, there are differences between the two and three wire thermostat versions, in the three wire type the 'anticipation' device (a heating element) is switched in parallel to the control circuit. In the two wire version, however, it is switched in series with the electrical gas control valve, so that the current through the valve passes through the device as well. Since the current consumption of such a valve will vary according to the type of heating, the device will either have to be adjusted to the system, or be made presettable to ensure the heat generated is at the right level. Thus, although two wire thermostats all include a non-presettable device (they are set by the manufacturer), the two wire version can be obtained with or without the preset feature. The non-presettable are designed for a specific system. The value of the device is usually mentioned somewhere on the inside of the thermostat and needs to correspond roughly to the current consumption indicated on the electrical gas valve.

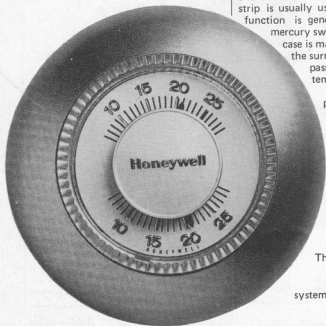

Some non-presettable types include a voltage stabiliser, so that the amount of heat generated by the device does not depend on the current passing through the valve. The presettable version can be adapted to the current consumption of the gas valve with the aid of a small lever. Figure 2 gives an example of this. The scale division may vary according to the manufacture, but usually the preset range will be between 0.1 and 1A. Weighing up the pros and cons of both systems, the two wire presettable type has important advantages. It is compatible with most types of central heating, so that if the boiler is changed, it merely has to be readjusted. This also means that if the system is not perfect, it can always be (slightly) modified.

Choosing the right system

The above description by no means implies that all you need is a good room thermostat for the central heating to work properly. An ideal compromise between comfort and economy is usually very hard to reach. Let us for instance look at an 'ordinary' system using a room thermostat based on a minimum outside temperature of -12°C and a room temperature of 22°C . Let us suppose the temperature outside varies to see what happens to the heat generated inside the living room and the bedroom at a required temperature of 15°C .

When the temperature outside is -12°C , the difference in temperature between indoors and out will be $22 + 12 = 34^{\circ}\text{C}$ with respect to the living room and $15 + 12 = 27^{\circ}\text{C}$ in the bedroom. This is the situation on which the power of the radiators is based. If, for example, the outside temperature rises to -4°C , the difference in temperature will be 26°C for the living room and 19°C for the bedroom. The living room requires heat to be generated with respect to the

former situation in a ratio of $\frac{26}{34} = 0.76$.

Since the heat production is regulated in the living room, the same 0.76 ratio will apply to the bedroom. The question is now whether this is necessary. If we consider this room in the two situations, the former will give us Δt of 27°C and the latter (-4°C) Δt of 19°C . The heat requirement ratio will therefore be $\frac{19}{27} = 0.70$. Quite a difference from that 'forced' on it by the living room!

Things are different when the outside temperature rises to $+6^{\circ}\text{C}$. The Δt for the living room will then be $22 - 6 = 16^{\circ}\text{C}$ and $15 - 6 = 9^{\circ}\text{C}$ for the other room. When the system is based on an outside temperature of -12°C , the living room will have a heat requirement ratio of $\frac{16}{34} = 0.47$. The

bedroom will again have this ratio forced on it, since temperature is regulated in the living room. This

1

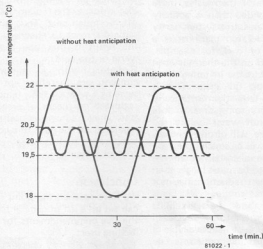

Figure 1. The delay in a central heating system can be reduced by providing the thermostat with an anticipation device.

actual requirements are in a ratio of $\frac{9}{27} = 0.33$. Clearly, it is overheated. The best way to save this energy is to install a radiator thermostat.

Radiator thermostats

A radiator thermostat stops the hot water supply when the required room temperature has been reached thereby maintaining the room's temperature at a constant level. When used efficiently, radiator thermostats ensure additional comfort and an effective system. One practical system consists of the following: 'Ordinary' radiators including air valves are installed in the living room. A room thermostat is also installed to act as a central switch for the whole house. Radiators including radiator thermostats are placed in the rooms where the temperature is to deviate from that of the living room. This means it is now possible to regulate the temperature separately here. At least,

provided a few things are borne in mind, for if radiator thermostats are to function properly, they must fulfil two conditions:

Firstly, the radiator will have to be a little larger than is strictly necessary, for otherwise the thermostat would be continually open and thus totally useless. Secondly, the circuit must produce hot water - if the living room doesn't require any heat, there won't be any available for the rest of the house either and there is nothing a radiator thermostat in the bedroom can do about it.

A system like the one described is very economical and, provided it is well balanced - it comes close to the 'ideal compromise'. Sometimes, however, it may not provide enough warmth. If, for instance, the living room is additionally heated by the sun through the entire system will become colder because the room thermostat will demand less warmth. Thus, a study which is used during the day and which happens to be in the shade will become very cold indeed.

In the latter case, it will mean heaving to increase the energy consumption in favour of a little more comfort. This can be done by replacing the room thermostat with radiator thermostats in every room, including the living room and in addition use a control system that is weather dependent (outside thermostat) as a pre-regulator. The latter needs to be preset so that the desired temperature is achieved in every room, winter and summer. The rest of the temperature regulation will now be taken care of by the radiator thermostats. This system costs a little more, energy-wise, but is ideal as far as comfort is concerned.

2

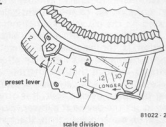

Figure 2. In the case of the two wire thermostat, the 'anticipation' device can usually be regulated.

Avoiding waste

When a room is being heated by a radiator and radiator thermostat, more heat will be provided than is actually needed in most cases. In a system partly equipped with radiator thermostats a night reduction of 5°C, for example, can be introduced on the thermostat in the living room, but the irritating delay problem will crop up again. This is because it will take thermostatically regulated radiators some time to lose their excess in hot water before the room temperature will drop. Furthermore, that delay will be smaller than the preser 5°C. If in a certain room the radiator happens to be much bigger than necessary, the night reduction may not take effect in that room at all. (This could be useful — think of a night child's room). The reason for this is that even the reduced amount of heat available is still to great for that radiator. The thermostat cannot change this, since it can only cut down on the amount in excess of its preset value.

This is therefore a clear example of energy being wasted. It can be avoided by making the night reduction much larger, or by presetting the radiator thermostats at a lower level at night too. Another form of wastage occurs when bedrooms are aired. The radiator thermostat must in any case be set at its minimum level, but even then the effect will not be the same as when a radiator tap is closed. If the outside temperature is lower than the minimum level of the thermostat (in winter) the radiator will start giving off heat while the room is being aired. Although it is difficult to avoid this dissipation, there are ways to reduce it to a minimum. In the first place of course by making sure the airing does not take too long. In the second by mounting radiator thermostats with various minimum ranges, using the lowest when airing the room. A crafty solution is to cover the thermostat with a cushion so that it can't feel the cold outside air.

A word on radiators

If a room is heated by a radiator system, the warmth will not only depend on the air temperature but also on the radiation factor. Both will have to be as constant as possible. If the temperature throughout the house is regulated by a room thermostat that fits in well with the system and this contains in addition a considerable amount of water, it is possible to maintain the temperature of the water within certain limits enabling the radiators to produce a fairly constant output.

Things are different when as often is the case nowadays, radiators with very low water contents are applied. When the heating is switched on, these heat up very quickly and so radiate a lot of heat. When the room cools off, however, they become cold very quickly, which isn't very pleasant. To remedy this the

thermostat is usually set at a higher level (at 22 or 23°C). If the heating is switched on again, it will again cause discomfort as the radiators will now give off too much heat. Thus, although such radiators react to changes very rapidly, the result is that you are either too warm or too cold.

Radiators with a minimum water contents are therefore not suitable, in systems where the temperature is regulated by means of a room thermostat. They are however useful in systems regulated on the basis of a constant pipe temperature such as a weather dependent control system.

Conclusion

We have reached the point now that we can set up a list of general requirements, the five commandments for any central heating user:

1. Always start by checking the special needs with regard to heating in the home. Only then can you find out what the ideal system would be. Is an 'ordinary' system with a single room thermostat suitable? Do certain rooms perhaps require a radiator thermostat?
2. Make sure the right type of radiator is being used. 'Fast' radiators have disadvantages as well!
3. Don't be too stingy about the installation costs. Technicians have a hard enough time as it is what with amateurs trying to set up their own systems. More often than not radiator thermostats are wrongly mounted. The sensor must not be situated in the rising warmth of the pipe or near the radiator itself and will therefore scan a totally wrong temperature. What also sometimes happens is that people forget to include a bypass pipe between supply and return in a system where all the radiators are fitted with thermostats valves. When all the valves are 'closed', no water movement will be possible in the circuit and the pump will overheat. Extremely bad for the pump, not to mention the boiler.
4. If the system has a two wire non-presettable thermostat check whether the 'anticipation' device matches the current consumption of the electrical gas valve. This check will not be necessary if it is a three wire type.
5. If the thermostat involves a presettable heat anticipation device, you will have to check whether the preset corresponds to the current value indicated on the gas valve. Sometimes it may be necessary to introduce a slight correction. If, for instance, the system is correctly regulated and the delay effect appears to be such that the thermostat only switched on and off once or twice during the space of one hour, it is often better to set the device at a lower value, by way of experiment, than the level indicated. Generally speaking an efficient system should switch about 5 or 6 times an hour for the room temperature to be maintained at a constant level.

december....

With Christmas and the festive season in mind, the December issue of Elektor promises something completely different.

The whole of the magazine is devoted to circuits designed entirely for fun with hardly a hint of any serious note at all. Some of the circuits are outrageous, even crazy, and strangely enough a few are extremely useful, but without exception, all are very ingenious.

They do however, all have one similarity, they are all designed to fit a common case.

What are they? Simple, they are circuits that can

But that would be spoiling the fun! Buy the December issue and find out for yourself, we guarantee you will enjoy it.

(They will be on the Elektor stand at Breadboard, come and see us, you're welcome.)

missing link

Nicad charger

Elektor 63/64 Summer Circuits 1980, circuit 49. The value of R3 should be 82 Ω, not 82 K!

✱

VFET amplifier

Elektor 63/64 Summer Circuits 1980, circuit 14. The substrate of IC1 (pin 13) must be connected to -36 V to maintain insulation between transistors and to provide for normal transistor action.

✱

Car alarm

The car alarm device which was published in Elektor's April issue ('Stop Thief') p. 4-28, unfortunately does not work exactly as described. With the alarm switched on, the engine stalls automatically after a few seconds, but it cannot then be started again — unless the 'hidden' switch is operated, of course. In order to 'simulate engine trouble' — so as to drive any prospective thief 'up the wall' — it is best to replace R1 by two 47 k resistors in series; the junction between these two resistors is then connected to pin 7 of the IC.

How can such motors be made to run more economically? When a fridge is designed all the worst possible events that could occur are taken into consideration. If for instance the mains voltage were to drop to 200 volts, the fridge should still continue to work. As a result of this foresight the motor chosen will more often than not be larger in size than strictly necessary. What happens is that they are not often 100% loaded so that a considerable amount of energy is irretrievably lost in the form of heat. The less loaded a motor, the higher the percentage of energy wasted. In completely unloaded motors up to 50% can be saved, whereas this is impossible if they are fully loaded.

An improvement in this situation is nothing new and in fact industry has

are connected together, in other words, a short circuit. The whole system may be regarded as a transformer in two parts. One half contains the case with the coils (the primary of the transformer) and the other is constituted by the rotor with the copper wire (the secondary side). The primary and secondary are separated by an air gap, but provided this is not too large, the device will still act like a transformer.

The secondary winding (the rotor) is short circuited! As soon as a voltage is connected to it, the primary will generate a field. This causes a voltage in the secondary as well, but since it is short circuited a large current will be generated. A wire situated in a magnetic field through which a current is passing will exert a mechanical force in a certain direction, according to elementary physics. The wires in the rotor are therefore pushed aside and the rotor starts to turn...

The field generated by the 'primary' rotates at a speed dependent on the frequency of the mains and on the way in which the motor is wound (the number of 'poles'). In any case the speed of this field will remain constant. The rotor will now be subjected to a magnetic force and unless it is braked it will start to rotate faster and faster until it is turning at the same speed as the field. At this point it will keep up with the field and so the latter will appear to it to be standing still, no longer changing. A non-changing field will however not cause induction, so that the current through the wires will decay and the rotor will no longer be driven. The rotor will of course still have some friction in the bearings and the speed will therefore drop slowly. Then there will be a difference in speed between the field and the rotor and the latter will be held at the same speed.

In actual fact, the above process happens very gradually. In a non-loaded state the rotor turns practically as fast as the field, so that it will hardly be driven at all. If the load of the rotor is increased, the driving power must also be greater. This can only be done if the rotor slows down to allow a magnetic force to affect it. Figure 1 shows a graph in which the relationship between speed and load is clearly apparent. The difference between the speed of the field and that of the rotor is termed slip. In a non-loaded state the slip will be slight; the more load, the more slip. If the motor is overloaded, the speed will drop suddenly. On the other hand, some motors are designed in such a way that the torque will continue to increase for a very long time (curve B). Most motors feature the characteristics of curve A. When there is a nominal load (the 100% line) the speed will drop between 5 and 10%.

How energy can be saved

Now we know the basic principles behind a short circuit motor, but still

energy-saving motor control

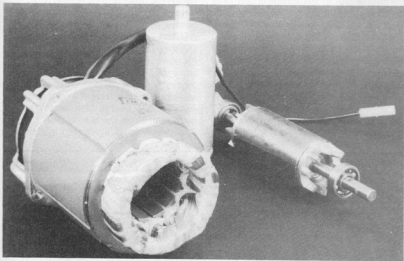

Improved motor control systems can cut consumption down by 50%. Incredible as it seems, this is perfectly true under certain circumstances in some of the biggest domestic appliances, such as fridges, ventilators and washing machines, for instance.

been making use of energy-saving motors for years. The present circuit, however, is based upon a radically different principle, for it gets rid of the source of the evil rather than correcting it later on with the aid of large capacitors switched in parallel, which is how the problem is normally taken care of.

How does a motor work?

Not all motors can be made to run economically. With the short circuit armature type, and luckily most domestic motors belong to this category, it can be done. This type of motor consists of a fixed ring of coils inside the case to generate a rotating magnetic field.

The rotor is made of iron to be highly inductive. The rotor also contains a certain amount of copper wire in the form of an armature, the ends of which

square wave voltages are produced out of voltage and current. Only if the two outputs are both 'high' at the same time will a current be able to flow into integrator A4 by way of D2. The pulse width of this signal will be equal to the shift between voltage and current. About 1/3 of the supply voltage will be at the non-inverting input of A4, whereas the inverting input will be grounded by way of P1, except when a pulse is generated via D2. A DC voltage level will appear at the output of A4 which will remain constant provided the average value of the signal at the non-inverting input is equal to that at the inverting input.

If the φ decreases (more motor load), the average signal at the inverting input will be reduced and the output voltage will therefore rise. This will cause the triac to be triggered sooner and the motor will therefore receive more power. A4 continues to regulate the system until the average voltages at its inputs are about equal again. Due to the large time constant of this integrator stage regulation happens gradually, rapid changes in load (and thus in the φ) cannot be followed.

The value of R9 depends on the current intake of the motor. A voltage drop of 0.35 (effective) across it is sufficient. Check this with a multimeter. P1 sets the required angle. Thus must be done slowly owing to the delay in reaction mentioned before. Check that the setting does not prevent the motor from starting up. C3 determines the integration time and can be increased in value if the motor does not run smoothly.

Conclusion

The circuit described here shows how much energy can be saved with electronics. When testing it is advisable to use an old motor and to wait until you're absolutely sure it works properly before inserting the circuit into your appliance.

Progress continues to be made in this field. It won't be long before an IC will be available with all the components required integrated on a single chip!

The principle of this energy-saving method was invented by Mr. Nola, a gentleman working for NASA. He is bound to have taken out a patent for it.

3

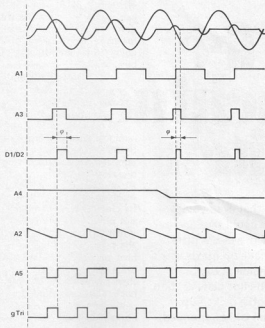

81036-3

Figure 3. The wave forms pertaining to the diagram shown in figure 2. The change in output of A4 has been drawn too short due to lack of space; in practice this will last for quite a few cycles.

4

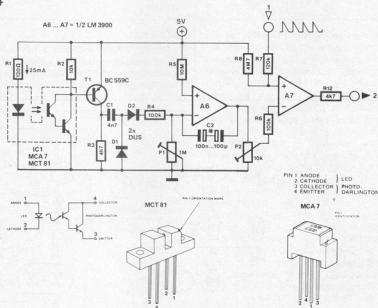

Figure 4. In our test circuit we used a paper disc with black and white stripes which were illuminated by LED D1. The reflected light was detected by the photo darlington T1. The speed may be adjusted with P1. P2 has been added to limit the maximum speed. C1 (4n7) determines the maximum input frequency of 150 Hz. By modifying C1 it is also possible to deal with other frequencies. A frequency that is twice as high will require a capacitor of half the size. C2 determines the regulation constant, the time delay it takes the circuit to react. This must be matched to the motor to ensure smooth running. If C2's size is to be such that an electrolytic capacitor is to be chosen, it is necessary to use two as drawn.

coffee machine switch

Did you know that even your coffee machine could save energy? With the aid of this clever little circuit it can make up for its user's forgetfulness, namely, by switching off the hot plate as soon as the coffee pot is picked up. A warning signal is then sounded, so that if the remaining coffee is to be kept warm a button must be pressed.

More and more people are taking to drinking coffee these days and coffee machines certainly prepare a good cup efficiently. They even keep your second cup warm for you. The trouble is, you don't always want another cup, which means a fair amount of electricity is going 'down the drain' — 500 watts to be exact.

This circuit switches the hot plate off automatically whenever the coffee pot is removed. When it is replaced a buzzing tone is heard as a reminder that the plate is no longer 'on'. If the coffee is to be kept at drinking temperature a button will have to be pressed.

A micro switch is mounted on the machine in such a position that it will be closed when the coffee pot is on the hot plate and open when it is removed. When switching on the coffee machine, the push button has to be operated to heat up the hot plate. This continues until the coffee pot is taken away, it then switches off. When the pot is put back, a buzzer sounds for a second as a reminder that the coffee will no longer be kept warm. If more coffee is to be drunk later, a button will have to be pressed. Then the hot plate will be 'on' until the coffee pot is removed again. In other words, the circuit is an 'active warning device'. First it is activated (switches off) and then it issues a warning (buzzes).

The circuit

The circuit shown in figure 1 has been kept as small as possible to enable it to be incorporated in the coffee machine. It can be split into two parts: an elec-

tronic zero-crossing switch (everything behind the opto-coupler IC2) and the section in front of it that detects the coffee pot and gives the warning.

Switch S1 is the micro switch which detects the presence of the coffee pot and is closed when the coffee pot is on the plate. The output of the flipflop built up with N2 and N3 has however not yet been defined. Operating push button S2 causes the output to become low. Then T2 will conduct and LED D3 (optical indication) and the LED in the opto-coupler will light. The thyristor in IC2 can then switch on the triac TR1 via the diode bridge D4...D7. Due to the presence of transistor T3, the photo thyristor can only switch on at the beginning of every half cycle of the mains supply. When the mains voltage reaches about 20 V, T3 will start to conduct causing the gate and the cathode of the photo thyristor to be short circuited so that this will switch off.

When the coffee pot is removed, S1 will open causing the flipflop N2, N3 to swing round and T2 to close. The photo thyristor will no longer be illuminated and the hot plate will be off. S1 will close again when the coffee pot is put back. During the RC time of C1 and R2 the output of N1 will become low so that transistor T1 will conduct and the buzzer will sound. With the values of C1 and R1 chosen here the buzzer will continue for about one second. Depressing S2 causes the output of the flipflop to become low again, T2 to conduct and the triac to switch on the hot plate.

Since the position of the flipflop depends on S1 and S2, the plate can only be switched on if S2 is operated after the coffee pot has been replaced.

The supply is very modest: a small

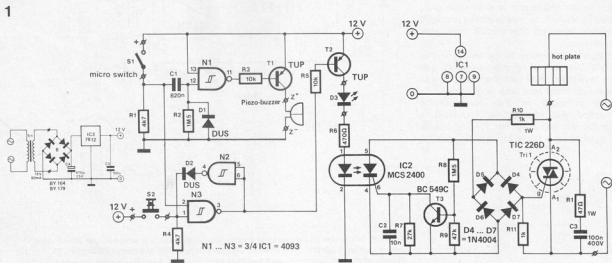

Figure 1. The circuit diagram of the switching-off device. To the left of the opto-coupler the low-voltage section takes care of detection and to the right the high-voltage section switches the circuit on during the zero-crossing.

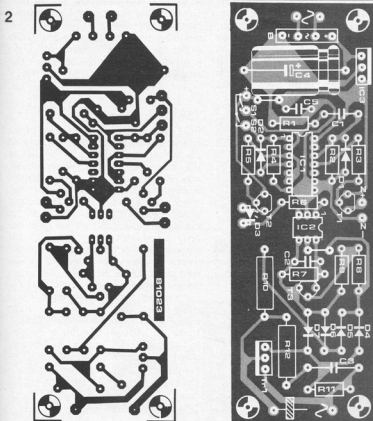

Figure 2. The component layout for the switching device. Only the transformer is yet to be included. It has been kept as small as possible in size so that it will easily fit into the coffee machine.

transformer, a bridge, a voltage regulator and a few capacitors.

The circuit board and construction

The layout of the printed circuit board

is shown in figure 2. One half contains the high-voltage section and the other low-voltage section with the opto-coupler between them. If there is enough room in the coffee machine, the board including the transformer can be

Parts list:

Resistors:

- R1, R4 = 4k7
- R2 = 1M5
- R3, R5 = 10 k
- R6 = 470 Ω
- R7 = 27 k
- R8 = 1M5
- R9 = 47 k
- R10 = 1 k, 1 watt
- R11 = 1 k
- R12 = 47 Ω , 1 watt

Capacitors:

- C1 = 820 n
- C2 = 10 n
- C3 = 100 n/400 V
- C4 = 470 μ /25 V
- C5 = 100 n

Semiconductors:

- T1, T2 = TUP
- T3 = BC 549C
- D1, D2 = DUS
- D3 = LED
- D4 ... D7 = 1N4004
- IC1 = 4093
- IC2 = MCS 2400
- IC3 = 7812
- T1 = TIC 226D

Miscellaneous:

- transformer 12 V, 50 mA
- bridge cell BY 164, BY 179
- Piezo-electric buzzer 12 V
- S1 = micro switch
- S2 = pushbutton 1 x type heatsink for the triac

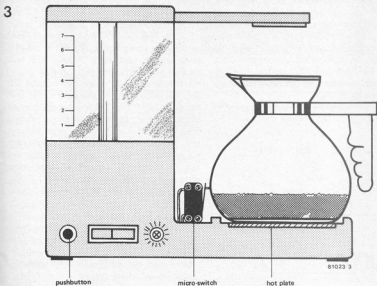

Figure 3. The drawing shows where to place the micro switch. The coffee pot is not in a fixed position on the hot plate, which will have to be taken into account.

built in. This is the most simple solution. The primary side of the transformer can be connected to the mains switch of the coffee maker. The two triac connection points on the board should then be connected in series with one supply lead to the hotplate. It should be noted that the triac will require a small heat sink to prevent it from becoming overheated.

Push button S2 is mounted on the coffee machine where it can be clearly seen and then a suitable place for the micro switch must be found. This will call for a little experimenting, for the coffee pot is not usually in a fixed position on the plate. It will largely depend on the design of the coffee maker, of course, but one method is given in figure 3 as a suggestion. No doubt our readers will devise other highly ingenious methods, as usual.

Should there not be enough room in the coffee machine, the board can be housed in a separate case together with switch S2. This has the disadvantage that it will require a cable between the machine and the case. It will have to be taken into account that half of the circuit board is carrying supply voltage and so extreme care must be taken.

Finally, a word on the buzzer. This is a piezo ceramic type with a low current consumption (only 15 mA). This is the only way to keep the circuit small and yet produce a loud enough tone. M

what is your central heating costing you?

operational hours counter

In the case of a device which only operates now and then, such as a central heating boiler for instance, it may be interesting to find out the true number of effective operational hours. For then the energy consumption per hour or the life of certain components can be calculated. This article describes an electronic operational hours counter which uses very little energy.

If it is known how many hours a central heating system (whether gas or oil) is in operation, it is a simple matter to determine how much energy can be saved by turning off one or several radiators. The number of operational hours can also indicate the correct time to switch from the day thermostat to the night and vice versa.

When experimenting with the radiators all that is needed to arrive at the most efficient setting, is a comparison of the number of operational hours before and

after adjustment. The different totals of operational hours per 24 hours will be in the same ratio as the energy consumption levels to each other. Obviously, the absolute value of the amount of energy consumed can also be calculated. If the heating system is oil fired that will be easy since the heating boiler is usually the only consumer unit connected to the oil tank. The number of litres used can be divided by the number of operational hours in order to obtain the amount of litres per hour. By multiplying that amount with the price per litre, the cost of an operational hour will be found.

As far as gas systems are concerned, it is often a little more complicated to calculate the price per hour because several systems (gas oven, fire) will be connected to the one gasmeter, so that the central heating system's consumption cannot be calculated separately. One method would be to switch off the other gasappliances, leaving the central heating on, and then read the gas meter for a period of, say, ten minutes. This can also be calculated per operational hour. To find out the central heating costs per quarter the operational hours counter can be used.

In order to determine the correct time to switch the thermostat from the day to the night level and vice versa, the minimum number of operational hours in the day time during which the house is comfortably warm can be empirically established.

The block diagram

Figure 1 shows the block diagram of the operational hours counter. The input of the circuit is connected in parallel to the thermostat switch. When closed, this switch starts an AMV (astable multivibrator) which has an output frequency of about 4.5 Hz. Its output signal reaches a divider which divides the signal by 2^{14} so that one pulse per hour is available. The output of the counter will be the number of clock pulses in binary. The outputs can be read with LEDs to make the information visible. Using a single LED for the reading may involve some calculation work, but on the other hand current consumption will be a lot lower. If the LED is used to indicate the output information via a pushbutton switch, the power consumption will be even less.

The circuit diagram

The circuit diagram of the operational hours counter is given in figure 2. Again with a view to saving energy CMOS-ICs are used. When the thermostat switch is open, C1 is charged. A1 will then be closed and the reset input of the 7555 will be grounded so that the AMV will be off. The hours counter will likewise be off. As soon as the thermostat switch closes, C1 will be discharged across R2 opening A1. Pin 4 of the 7555 is then taken high and the AMV will start to operate. Its frequency should be set to 4.5 Hz with the aid of P1. Pin 3 of the 7555 is connected to the clock input of IC2. The Q14 output of this IC will generate a pulse every hour if the AMV is properly regulated. Thus, IC3 will receive a clock pulse every hour.

At the first clock pulse the output Q0 will become high. At the second Q1 will become high and Q0 low again and so on in a binary format. For those readers who are not too familiar with binary, the values of all twelve outputs are given in the table. If several outputs are '1', the (decimal) values of those outputs are added to each other. Thus, 000001010010 : $2 + 16 + 64 = 82$ hours.

The LED D3 will indicate which outputs are high when pushbutton S2 is operated. The switch S3 enables each output to be selected in turn. If a selected output is high, A2 will be closed and the LED will light when S2 is depressed. If an output is low, A2 will be open and the LED will not light, even if S2 is depressed. Depressing S1 will cause the counter to be reset and start counting from zero again.

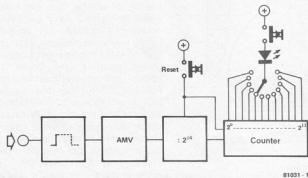

Figure 1. The block diagram of the operational hours counter.

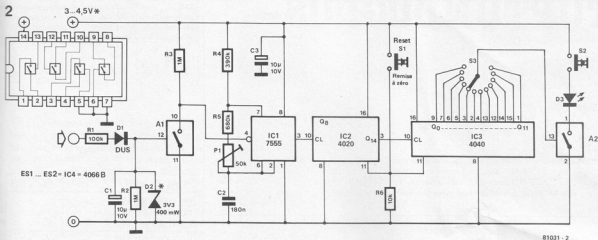

Figure 2. The complete circuit diagram of the operational hours counter.

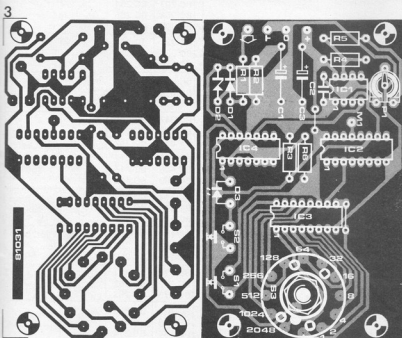

Figure 3. The component and copper layout of the printed circuit board.

Parts list

Resistors:

R1 = 100 k
 R2, R3 = 1 M
 R4 = 390 k
 R5 = 680 k
 R6 = 10 k
 P1 = 50 k (47 k) preset

Capacitors:

C1, C3 = 10 µ/10 V
 C2 = 180 n

Semiconductors:

D1 = DUS
 D2 = 3V3/400 mW zener diode
 (see text)
 D3 = LED red
 IC1 = 7555
 IC2 = 4020
 IC3 = 4040
 IC4 = A1 ... A4 = 4066B

Miscellaneous:

S1, S2 = single pole pushbutton
 S3 = 12 position switch

The construction

Figure 3 shows the printed circuit board on which the circuit can be mounted. The input is connected to the thermostat switch by means of wires. The supply can be provided by two or three penlight cells in series or by means of a single 4.5 V battery. The batteries last for quite a long time because the LED of course only has to light occasionally and the quiescent current consumption is not more than 45 µA. Zener diode D2 should have a slightly higher value than the supply voltage. At a supply of 3 volts, 3.3 V is a good value, at 4.5 volts, a 4.7 V zener will be required. The best way to set P1 is to use output Q8 of IC2. This output should change in level after about every 28 seconds

Table 1

Q11	Q10	Q9	Q8	Q7	Q6	Q5	Q4	Q3	Q2	Q1	Q0
2 ¹¹	2 ¹⁰	2 ⁹	2 ⁸	2 ⁷	2 ⁶	2 ⁵	2 ⁴	2 ³	2 ²	2 ¹	2 ⁰
2048	1024	512	256	128	64	32	16	8	4	2	1

(1 cycle per 56½ seconds) if P1 is correctly set. Once this has been achieved, P1 can be locked with glue or nail varnish. The frequency of the AMV is independent of the supply voltage, in other words at lower battery voltages the count will still be correct. The entire unit may be fitted in a plastic case with the switches mounted so that

they are easily accessible and the LED placed where it is clearly visible. The circuit can of course also be used to count the operational hours of other devices as well as the central heating. To adapt it to other circuits another two switches (A3 and A4) can be used. The pins 5 and 6 belonging to them will then obviously not be grounded.

TUPTUNDUGDUS

Wherever possible in Elektor circuits, transistors and diodes are simply marked 'TUP' (Transistors, Universal PNP), 'TUN' (Transistor, Universal NPN), 'DUG' (Diode, Universal Germanium) or 'DUS' (Diode, Universal Silicon). This indicates that a large group of similar devices can be used, provided they meet the minimum specifications in tables 1a and 1b.

	type	U_{CE0} max	I_C max	h_{fe} min.	P_{tot} max	f_T min.
TUN	NPN	20 V	100 mA	100	100 mW	100 MHz
TUP	PNP	20 V	100 mA	100	100 mW	100 MHz

Table 1a. Minimum specifications for TUP and TUN.

Table 1b. Minimum specifications for DUS and DUG.

	type	U_R max	I_F max	I_R max	P_{tot} max	C_D max
DUS	Si	25 V	100 mA	1 μ A	250 mW	5 pF
DUG	Ge	20 V	35 mA	100 μ A	250 mW	10 pF

Table 2. Various transistor types that meet the TUN specifications.

TUN		
BC 107	BC 208	BC 384
BC 108	BC 209	BC 407
BC 109	BC 237	BC 408
BC 147	BC 238	BC 409
BC 148	BC 239	BC 413
BC 149	BC 317	BC 414
BC 171	BC 318	BC 547
BC 172	BC 319	BC 548
BC 173	BC 347	BC 549
BC 182	BC 348	BC 582
BC 183	BC 349	BC 583
BC 184	BC 382	BC 584
BC 207	BC 383	

Table 3. Various transistor types that meet the TUP specifications.

TUP		
BC 157	BC 253	BC 352
BC 158	BC 261	BC 415
BC 177	BC 262	BC 416
BC 178	BC 263	BC 417
BC 204	BC 307	BC 418
BC 205	BC 308	BC 419
BC 206	BC 309	BC 512
BC 212	BC 320	BC 513
BC 213	BC 321	BC 514
BC 214	BC 322	BC 557
BC 251	BC 350	BC 558
BC 252	BC 351	BC 559

The letters after the type number denote the current gain:

- A: α' (β , h_{fe}) = 125-260
 B: α' = 240-500
 C: α' = 450-900.

Table 4. Various diodes that meet the DUS or DUG specifications.

DUS		DUG
BA 127	BA 318	OA 85
BA 217	BAX 13	OA 91
BA 218	BAY 61	OA 95
BA 221	1N914	AA 116
BA 222	1N4148	
BA 317		

Table 5. Minimum specifications for the BC107, -108, -109 and BC177, -178, -179 families (according to the Pro-Electron standard). Note that the BC179 does not necessarily meet the TUP specification ($I_{C,max} = 50$ mA).

	NPN	PNP
		BC 107 BC 108 BC 109
U_{CE0} max	45 V 20 V 20 V	45 V 25 V 20 V
U_{EB0} max	6 V 5 V 5 V	5 V 5 V 5 V
I_C max	100 mA 100 mA 100 mA	100 mA 100 mA 50 mA
P_{tot} max	300 mW 300 mW 300 mW	300 mW 300 mW 300 mW
f_T min.	150 MHz 150 MHz 150 MHz	130 MHz 130 MHz 130 MHz
F	10 dB 10 dB 4 dB	10 dB 10 dB 4 dB

Table 6. Various equivalents for the BC107, -108, ... families. The data are those given by the Pro-Electron standard; individual manufacturers will sometimes give better specifications for their own products.

NPN	PNP	Case	Remarks
BC 107 BC 108 BC 109	BC 177 BC 178 BC 179		
BC 147 BC 148 BC 149	BC 157 BC 158 BC 159		$P_{max} = 250$ mW
BC 207 BC 208 BC 209	BC 204 BC 205 BC 206		
BC 237 BC 238 BC 239	BC 307 BC 308 BC 309		
BC 317 BC 318 BC 319	BC 320 BC 321 BC 322		$I_{C,max} = 150$ mA
BC 347 BC 348 BC 349	BC 350 BC 351 BC 352		
BC 407 BC 408 BC 409	BC 417 BC 418 BC 419		$P_{max} = 250$ mW
BC 547 BC 548 BC 549	BC 557 BC 558 BC 559		$P_{max} = 500$ mW
BC 167 BC 168 BC 169	BC 257 BC 258 BC 259		169/259 $I_{C,max} = 50$ mA
BC 171 BC 172 BC 173	BC 251 BC 252 BC 253		251...253 low noise
BC 182 BC 183 BC 184	BC 212 BC 213 BC 214		$I_{C,max} = 200$ mA
BC 582 BC 583 BC 584	BC 512 BC 513 BC 514		$I_{C,max} = 200$ mA
BC 414 BC 414 BC 414	BC 416 BC 416 BC 416		low noise
BC 413 BC 413	BC 415 BC 415		low noise
BC 382 BC 383 BC 384			
BC 437 BC 438 BC 439			$P_{max} = 220$ mW
BC 467 BC 468 BC 469			$P_{max} = 220$ mW
	BC 261 BC 262 BC 263		low noise

market

DIL changeover switches

The Erg SDC range of spring loaded DIL-switches have switching contacts that are hard gold plated on nickel to give reliable and repeatable switching operations. With non-switching voltage ratings from 1 μ V to 100 V (current 1 μ A to 1 A), and switching ratings up to 10 VA, these high reliability components have an initial contact resistance of 8 m Ω typical at 10 mV/10 mA max. Storage and working temperatures range from -55 to +100°C. Erg DILswitches feature a high insulation resistance (100 G Ω at 500 V DC) with dielectric strength tested for 60 s at



500 V RMS 50 Hz. Of modular design, a single c.o. DILswitch measures only 8.9 x 10.6 mm. Any number may be fitted side by side on a standard 2.54 mm pitch without loss of space. These DILswitches are available as single switch modules or in multiples comprising 2, 3, 4 or 5 switches contained in a single, compact package. Switching actuators are both colour coded and numbered for fast identification of individual switch status.

Erg Components,
Luton Road,
Dunstable,
Beds LU5 4LJ.
Telephone: (0582) 62241

(1636 M)

Audio frequency test meters

The first ever hand-held digital level meter capable of making weighted and unweighted noise measurements on telephone channels to CCITT recommendations, as well as being able to measure signal levels from -70 to +10 dBm on telephone and audio channels over the frequency range 30 Hz to 20 kHz, has been introduced by Wandel & Goltermann (UK) Ltd., London.

Designated PMP-20, the meter is to be marketed alongside a similar meter, the PM-20, which does not have the noise measurement capability, but which can measure very high levels from -50 up to +30 dB over the extended frequency range 15 Hz to 20 kHz. Resolution is 0.1 dB for both noise and level readings. Two switchable impedances are provided at 600 ohms and 100 k.ohms for terminated and through measurements.

Both meters are lightweight, portable instruments which will also measure DC voltages from zero to 100 V (± 0.1 V). Autoranging and a large digital display, always



showing the correct sign, allow repetitive values to be read quickly and easily. Housed in a rugged, shock-proof case, the meters are powered by an internal dry battery, or alternatively a rechargeable nickel-cadmium cell. A warning arrow starts to flash two hours before the battery is discharged, and if the voltage drops further, the meter switches itself off to avoid erroneous readings.

Wandel & Goltermann (UK) Ltd.,
40 - 48 High Street,
Acton,
London, W.3.,
Telephone: 01-992 6791.

(1627 M)

Digital readout power supplies

Precision power supplies just announced by Havant Instruments are believed to be the first offering digital monitoring of voltage and current. The PL 310 uses two 3 $\frac{1}{2}$ -digit displays to provide a resolution of 10 mV at all settings from 0 to 30 volts, and of 1 mA at all current levels from 0 to 1 amp. To realise the full value of such an accurate readout, the supplies utilise band-gap voltage reference diodes, in place of the usual zener diodes, for voltage and current stabilisation.



Separate terminals are provided for the fully floating output and for the sensing circuits - allowing precise monitoring of the conditions at a remote load. A switch caters for no-load voltage and current limit setting without alteration to external wiring. There is also a damping switch, enabling mean current levels to be read with fluctuating loads. The PL 320K incorporates a 5 volt 7 amp output with ± 1 volt variability, remote sense,



and a user adjustable overvoltage protection crowbar. Two further outputs are available, each of which can be set between 0 and 30 volts at currents of up to 2 amps. Suitable for 110 or 240-volt nominal supplies, the PL series achieve a line stability of better than 0.01% of max. o/p for a 10% change, and a load regulation of better than 0.01% of max. o/p for a 50% change. Ripple is typically below 1 mA and the transient response is less than 20 microseconds for stabilisation to within 50 mV following a 100% load change. Automatic indication occurs when the unit commences to operate in a constant current mode. This level can be set anywhere from 0 to 110% of the rated maximum output.

Havant Instruments Ltd.,
Unit 3, Westfisks, Portsmouth Road,
Horndean, Hants.
Tel: (0705) 596020/596045
Telex: 86845

(1639 M)

Photodiode arrays for position detection

The Symot 320/2 range of photodiodes now includes type PN-100-1. This comprises 100 photodiodes, each of which, under test conditions of 1000 Lux has photo-voltage 0.38 V and photocurrent 13 V, at 1000 Lux

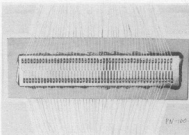

and 25°C. The dark current is 0.01 mA at 3 V and the capacitance 130 pF. The elements are spaced at 1.0 mm pitch (centre to centre) and the peak sensitivity is at 830 nm. This photodiode array is particularly suitable for use in edge position detection, pattern reading, and also in shaft encoder applications.

Symot Limited,
22a Reading Road,
Henley on Thames,
Oxon RG9 1AG,
Tel: (049 12) 2663,
Tlx: 847333 SYMOT G

(1628 M)

market

Remote control garage door operator

The NuTone computerised garage door operator, is now newly available, throughout the U.K., from the Haos Company Ltd., of Bromley, Kent. It offers advantages over systems already on the market in that it is advanced, both technically and in appearance; more secure; operates from the greater distance of 400 yards; has a computer that does its own adjustments (to help the do-it-yourself installer); and is competitively priced.

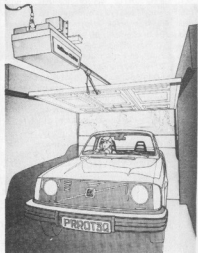

This garage door opener will fit most up-and-over garage doors: it is simply installed by the do-it-yourselfer, (using step-by-step instructions), local electrician or builder or Haos agent. In response to a signal from the hand control, it has the facility to open a heavy garage door, turn on the light, allowing the driver sufficient time to get out of the car and leave the garage, automatically turn off the light, and close and securely lock the door.

*The Haos Company Ltd,
The Built-In Centre,
32 Leitchworth Drive,
Bromley,
Kent
(tel.: 01 460 2136).*

(1685 M)

Economical medium-size enclosures

OK's series CL PacTec enclosures provide instrument and electronics manufacturers and designers with a creative and adaptable, medium- to large-size enclosure package at a considerably lower cost than made-to-measure moulded plastic or fabricated metal enclosure.

The CL enclosures are ideal for oscilloscopes, strip recorders, minicomputers, printers, large amplifiers, medical instruments and larger power supplies, as well as for many other

applications. They measure 317.5 mm (12.5 in) wide, 295.3 mm (11.63 in) deep, and are available in heights from 114.6 mm (4.51 in) to 146.3 mm (5.76 in).

Moulded from heavy-weight ABS material the units are attractive, durable, strong, and impact resistant, and use a special system of internal mounting bosses, PC card guides, mounting rails, accessories, and other hardware to give the designer the unlimited flexibility in creating precisely the custom enclosure he needs. In addition, he can create an attractive custom with three-dimensionally moulded front panels which can also incorporate production features such as posts, clips and slots.



The range is available in four standard colours — blue, tan, black and grey — plus fifteen special colours. Options include custom trim, special finishes, special bezels, strap handle, EMI and RFI shielding, construction from UL listed material, sloped top or bottom cover, rear panel extensions and card guides and mounting rails. Tilt stands can also be supplied.

The CL enclosures enable the user to create prototypes, easily and inexpensively, using low-cost designer kits. Depending on which kit is selected, it can contain top and bottom covers, side panels, front and rear panels (which can be drilled, cut, punched and silkscreened), card guides, mounting rails, hardware and a tilt stand. The user simply selects the size case needed, picks the hardware and accessories from the kit necessary to mount components and easily assembles the case.

*OK Machine & Tool (UK) Ltd.,
Dutton Lane, Eastleigh,
Hants SO5 4AA,
Tel: 0703 - 610944.*

(1678 M)

Miniature terminal strip has 7A rating

A series of miniature barrier terminal strips are available for applications in electrical and electronic equipment and instrumentation such as modular power supplies.

The M24F is a range of miniature barrier terminal strips offering a wide range of cavity and termination possibilities. While compact in design, they present no compromise to electrical safety: their 3 mm high barriers are proofed at up to 7 A at 6.2 kV, depending upon the types of termination fitted, and permit working voltages of up to 1 kV r.m.s. The overall dimensions of the strip are 8.5 mm high x 16.0 mm deep, with up to 14 cavities on 6.35 mm centres. End fixing is by unthreaded holes, which can be fitted with terminations according to individual user requirements.

A variety of termination styles may be incorporated on the M24F. These include

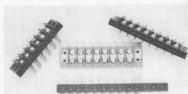

screw, solder tail and printed circuit types, together with a fanning strip of up to 14 ways. The M24F miniature barrier terminal strip is moulded in either blue gas-filled nylon, or black glass-filled nylon or polyester UL 94 V-0 rated to +120°C, according to application requirements.

*H & T Components,
Crowdy's Hill Estate,
Kembrey Street,
Swindon,
Wiltshire SN2 6BN.
Tel. (0793) 693681-7.*

(1688 M)

Flexible copper clad laminates from 3M

CuFlex 6550 flexible copper clad laminates — a new range — has been introduced by 3M United Kingdom Ltd's Electronic Products Group for the production of high quality flexible printed circuit boards.

The CuFlex flexible copper clad dielectric consists of a flexible flame retardant epoxy/polyester resin, reinforced by an organic fibre non-woven web. It has all the properties to provide the highest quality printed circuits. These properties include good adhesion to copper, good thermal and dimensional stability, solder ability, mechanical strength, flame retardancy and the ability to produce reliable plated through holes.

Other qualities include a high peel strength eliminating the need for covercoats in certain applications, good dimensional stability, high tear resistance and the ability to mount components without rigidising. It can also be wave soldered — without blistering — at 260°C for 10 seconds.

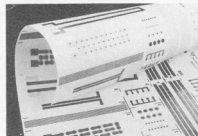

CuFlex 6550 flexible circuitry is currently being used in military and aerospace applications, computers, instrumentation and in telecommunications. Other major areas of application include telephone handsets, back plane wiring, electronic switching and speaker phones.

*Products Group,
3M United Kingdom Ltd.,
3M House,
PO Box 1,
Bracknell,
Berks RG12 1JU.
Tel.: (0344) 58436*

(1686 M)

market

Silicon photodiodes

The Centronic TOP TEN collection of silicon photodiodes is a range of advanced specification devices carefully selected to cover a wide field of applications. Offered at very competitive prices, they are not merely mass produced items but conform strictly to their specification.

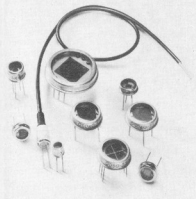

The uses are as diverse as colour grading, energy monitoring camera exposure control, precision positioning - typically $< 1 \mu\text{m}$, - optical surveying, laser alignment, temperature sensing, missile guidance, optical star sensing, fibre-optic communications and modems.

Included are the fast, high-sensitivity BP x 65 - which can also be supplied in chip form for maximum utilisation, - the 'eye-response' BPW 21, the 100 sq mm area OSD 100-5T, the position-sensing dual-element LD 2-5T, the quadrant QD 50-5T and the single-element hybrid OSI-5K. A speciality is the PP 65-25 having optical input by way of a 25 cm length of plastic fibre.

Centronic,
Centronic House,
King Henry's Drive,
New Addington, Croydon,
CR9 0BG England.
Tel: (0689) 42121/8

(1692 M)

New two-tone brown case boxes

To complement their comprehensive range of two-tone grey plastic Veroboxes, Vero Electronics Limited have introduced two models in an attractive two-tone brown colour scheme.

The first is a Type I Verobox with an overall width of 205 mm, height of 75 mm and depth of 140 mm. Consisting of a top and bottom section held together by four screws which enter through the plastic feet located on the base, it includes front and rear panels and fixing points for horizontally mounted printed circuit boards or chassis plates.

The second is a Type III Verobox with an

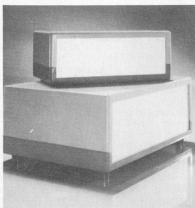

overall width of 154 mm, height of 60 mm and depth of 85 mm. This box has a unique clip-together design which requires no fixing screws, the front and rear panels are retained in position when the two halves are assembled and four stick-on feet are provided. Printed circuit boards can also be mounted vertically in the same plane as the front panels.

Both models are moulded in high impact polystyrene and incorporate anodised aluminium front and rear panels that can be machined, engraved or silk screened.

Vero Electronics Limited,
Industrial Estate,
Chandlers Ford,
Eastleigh,
Hampshire SO5 3ZR
Tel.: (04215) 66300

(1690 M)

Digital clip-on wattmeter

The model 2433 is a new instrument and thought to be the first clip-on wattmeter to be introduced to the U.K. market. With a LCD digital readout, the instrument will measure volts up to 600 V, amps with a 20 A or 200 A version and watts 20 kW or 200 kW, it is auto-ranging on all measuring ranges and accuracy is 1%. True R.M.S. AC measuring circuits are used enabling accurate determination of distorted waveforms such as thyristor outputs. Single phase and balanced three phase circuits may be monitored.

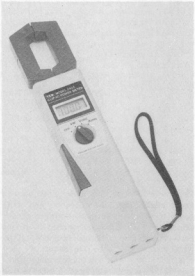

Battery option gives 15 hrs continuous use and an analogue output is provided for recording purposes.

The 2433 will be particularly useful for energy studies and power service supervision.

Martron Ltd.,
20 Park St., Princes Risborough, Bucks,
Tel: (08444) 4321.

(1681 M)

The ultimate caliper?

This digital caliper according to comprehensive, tests reduces reading time by 50% and the spread of readings by as much as 90%. Furthermore it requires no operator training time and it is just as handily sized as any traditional vernier or dial caliper.

JOCAL, which is the name of this new instrument, can be zero-set anywhere within the 150 mm (6") measuring range. This enables measuring of variations from reference size, measuring of centre distance between two identical holes etc. It also has an inch/metric switch option.

The JOCAL is based on a completely new, patented scale/transducer system plus a specially designed IC-circuit. The measurement is shown digitally on an LCD display with 0,01 mm (± 0.0005 ") resolution over the whole measuring range. The patented electronics plus the automatic switch-off 2 min. after the last measurement contribute to a battery life of more than 12 months with regular use.

The design of the JOCAL makes it insensitive to dust, oil, filings, shavings or other impurities

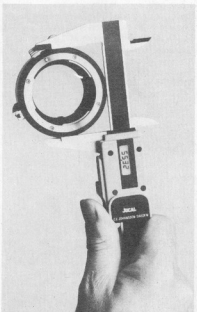

prevailing on the workshop floor. Its advanced semiconductor technique makes it also insensitive to surrounding electronic and magnetic interferences, which previously caused serious problems with other electronic instruments.

C.E. Johansson Limited,
66, High Street,
Houghton Regis,
Dunstable, Beds. LU5 5BJ,
England,
Tel.: Dunstable 68 181

(1689 M)

market

Weighing only 8.5 Kgm, and complete with low-capacitance probes, the LBO-520A is available from Sinclair Electronics Ltd. at £ 475.00.

Sinclair Electronics Ltd.,
London Road, St. Ives,
Huntingdon, Cambs PE17 4HJ,
Tel: (0480) 64646.

Precision planetary gearbox

A new gearbox has been designed and made utilising the very latest available technology. Known as the R22 precision planetary gearbox, it is available with two or three gear stages and a range of six different ratios from 16.2:1 to 190:1. It has torque rating of 0.6 Nm (85 oz. ins). The diameter is 22 mm; for ratios up to 33.1:1 the length is 32.5 mm, and for ratios up to 190:1, it is 40 mm.

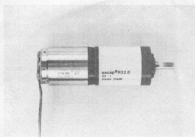

To ensure reliable and trouble-free operation, the R22 is made with hardened steel shafts and pinions and the stainless-steel output shaft runs in pre-lubricated sintered bronze sleeve bearings; the satellite wheels and housing are moulded from synthetic materials. This new gearbox can be fitted to the 22, 23, 26 and 28 PL series of d.c. motors.

Portescap (U.K.) Limited,
204 Elgar Road,
Reading, RG2 0DD.
Tel: (0734) 861 485/6/7/8

(1691 M)

LBO-520A - New oscilloscope from Leader

The LBO-520A dual-trace oscilloscope from Leader provides all the features required of a wide-band laboratory instrument at a highly attractive price. With a 5" rectangular screen, using the latest PDA CRT technology, this dual-trace unit also boasts a 5 mV sensitivity and a true 35 MHz bandwidth. In addition, a built-in signal delay line ensures ease of viewing those fast leading edges, whilst all-round versatility is assured by the most comprehensive trigger facilities.

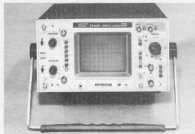

TM352 — New hand held LCD multimeter from Thandar

Sinclair Electronics announce the latest product in the Thandar range of low-cost, portable test equipment. The TM352 is a battery operated 3½ digit hand-held multimeter with a large 0.5" liquid crystal display. With an input impedance of 10 MΩ, it covers 16 ranges, including DC voltage (100 μV - 1000 V), AC voltage (100 mV - 1000 V), DC current (100 nA - 10 A), resistance (1 Ω - 20 MΩ). Also featured are an audible continuity check and an hFE measurement facility.



(1676 M)

(1675 M)

Push button controls allow rapid and easy operation, whilst compact size, robust construction and long battery life (typically > 150 hours) make the TM352 truly portable. The TM352, complete with battery, test leads and a full 1-year warranty costs £ 49.95. Sinclair Electronics Ltd., London Road, St. Ives, Huntingdon, Cambs PE17 4HJ, Tel: (0480) 64646.

at 1064 nm and 85 A/W at 900 nm, rise and fall times of 1.2 nanoseconds and NEP's of 3×10^{-12} W/√Hz at 1964 nm.

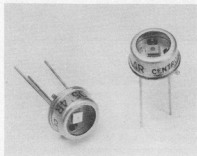

The unit is designed for operating over the temperature range -40°C to +70°C and is assembled in a low profile isolated TO-5 package for applications which include laser range finding, laser proximity fusing and fibre-optic communications.

Centronic, Centronic House,
King Henry's Drive,
New Addington,
Croydon, CR9 0BG England,
Tel: (0689) 42121/8.

(1677 M)

DILswitch modules

The Erg SDC4 DILswitch module contains four, two-pole changeover dual in-line switches. Each switching member has its own, unique colour and is also individually numbered. This, together with the comparatively large size switching members, makes the components very easy to use. The status of all switches is also very quickly distinguished at a glance. All switches have contact ratings of

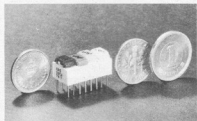

1 μV to 100 V, 1 μA to 1 A (10 VA maximum switching). Initial contact resistance is 8 mΩ typical, while insulation resistance is 100 GΩ. The switches have a break-before-make action and the modules may be mounted side by side on a standard 0.1 in pcb pitch without loss of space.

Erg Industrial Corporation Ltd.,
Luton Road, Dunstable, Bedfordshire,
LU5 4LJ England,
Tel: 0582 - 62241.

(1679 M)

Avalanche photodetector APD05-4R

Centronic has applied modern semiconductor technology with the use of ion implantation, silicon nitride passivation and a totally depleted flip-chip precision assembly for this reach-through avalanche photodiode.

The premium unit of the two grades offered has typical parameters: responsivity 23 A/W

market

market

Low cost modular pcb connectors from UECL

Two new low cost pcb connector series have been introduced by Ultra Electronic Components Limited. The series 1585 and series 1855 are both modular 0.1 inch pitch types with from 5 to 85 ways (single-sided) or 10 to 170 ways (double-sided).

The contacts are of cantilever design and are selectively gold plated to reduce the volume of redundant gold on areas other than the point of contact. Five types of terminal post are offered, suitable for hand soldering, wire wrap and flow soldering (three types). Solder terminals are tin plated and wire wrap terminals gold plated.

The two series only differ in moulding material. Series 1585 uses a thermoplastic polyester moulding, with higher stability DAP being used for series 1855. Operating temperature range for both series is -55°C to $+125^{\circ}\text{C}$.

Contacts are designed to give consistent insertion and withdrawal forces, and a mechanical endurance of up to 100 matings with $0.5\ \mu\text{m}$ gold plating (250 matings with $1.8\ \mu\text{m}$ plating). As with other UECL connectors, these types have been tested in the Company's own B.S.9000 and D.Q.A.B. Approved test house to relevant B.S.9000 specifications.

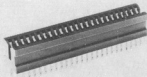

(1682 M)

Applications are varied and include computer and microcomputer peripherals, commercial instrumentation, professional assemblies and other high reliability non-military equipment.

Ultra Electronic Components Ltd.,
Fassetts Road, Loudwater,
High Wycombe, Bucks,
Tel: 0494-26233.

High-accuracy Sample-Hold amplifier

Precision Monolithics introduces the SMP-11, a data-acquisition sample-and-hold amplifier featuring 0.015% accuracy and a low combined offset voltage and step transfer error of 0.45 mV. The SMP-11 employs a diode bridge switch design which minimizes charge transfer errors.

Typical acquisition time is $3.5\ \mu\text{s}$ and slew rate is typically $10\ \text{V}/\mu\text{s}$. A unique transcon-

ductance amplifier (super-charger) enhances the diode bridge switch during acquisition by providing up to 50 mA of charging current to the hold capacitor. The super-charger turns off as the S/H amplifier acquires the signal. As a result, smooth charging of the hold is achieved with minimum noise. The super-charger, in conjunction with the device's high-slewing rate input and output buffer amplifiers, permits fast acquisition operation. Because it uses a bipolar Darlington amplifier input stage, the SMP-11 maintains low droop rate over the entire operating temperature range. Most sample-and-hold amplifiers employ FETs to obtain low droop currents at 25°C . However, the droop current for FET amplifiers double every 10°C rise in temperature whereas the SMP-11's droop current actually decreases for temperatures up to 70°C or more.

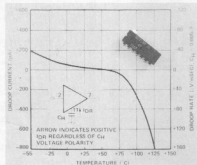

Other important characteristics of the SMP-11 are a low aperture time of 50 ns, low hold mode settle time of $1.5\ \mu\text{s}$, a high sample current/hold current ratio of 1.7×10^5 and compatibility with DTL, TTL, and CMOS logic.

The SMP-11 comes in a 14 pin DIP and is available in both military and commercial operating temperature ranges.

Bours AG,
Baar,
Switzerland
Tel. 042.33.33.33

(1683 M)

market

10 kHz to 100 MHz USB/LSB transceiver building block

Ambit's 91600 receiver is based on an SL 1600 series Plessey application design by James Bryant - modified to accept an 8-pole 10.7 MHz SSB crystal filter to enable the frequency offset of the system to be used with the Ambit DFM 7 LCD frequency readout module for 1 kHz resolution in the HF bands.

By using the correct first mixer, the range 10 kHz to 100 MHz may be spanned - although for most users, the standard 1 - 500 MHz range is quite sufficient. The unit provides approx. 10 mW of SSB in transmit mode, and a complete SSB receiver with 1 W output stage.

An external local oscillator and bandpass

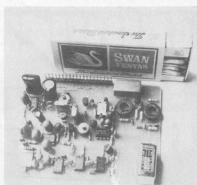

filter/preselector is required to cover the frequency band desired - full USB/LSB switching is provided on the board.

Priced around £40,000 (in kit form), the 91600 offers a versatile basis for SSB TX/RX systems for HF to UHF.

Ambit International,
200 North Service Road,
Brentwood,
Essex. CM14 4SG,
tel. (0277) 230909.

(1687 M)

Microspeech 2

Microspeech 2 is a stand alone speech synthesizing unit. It converts phonetic code or any text (which is input via a standard RS 232 connection) into a speech output. Microspeech 2 may be interfaced to any computer system because all the computation necessary to synthesize speech is performed by its own dedicated microprocessor. In fact it is possible to run the unit from just an ASCII keyboard. Up to one thousand phonetic characters, representing about one minute of speech, may be assembled in the units internal buffer before it is commanded to speak. The controlling microprocessor has a spare ROM capability of 8K bytes which can be used to store an optional text to phonetics translator program. This includes the phonetic equivalents of all the standard ASCII symbols,



and thus enables the unit to be driven directly from English text. Although the speech in this mode is less fluent than that produced in the phonetic mode, it does allow messages to be rapidly programmed, and also makes the unit extremely useful to the blind.

Cosronics Electronics,
13 Field Heath Avenue,
Hillingdon,
Middlesex
Tel: (89) 38791

(1684 M)

SERVICES TO READERS

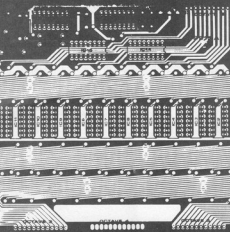

EPS print service

Many Elektor circuits are accompanied by printed circuit designs. Some of these designs, but not all, are also available as ready-etched and pre-drilled boards, which can be ordered from any of our offices. A complete list of the available boards is published under the heading 'EPS print service' in every issue. Delivery time is approximately three weeks.

It should be noted however that only boards which have at some time been published in the EPS list are available; the fact that a design for a board is published in a particular article does not necessarily imply that it can be supplied by Elektor.

Technical queries

Please enclose a stamped, self-addressed envelope; readers outside UK please enclose an IRC instead of stamps.

Letters should be addressed to the department concerned — TQE (Technical Queries). Although we feel that this is an essential service to readers, we regret that certain restrictions are necessary:

1. Questions that are not related to articles published in Elektor cannot be answered.
2. Questions concerning the connection of Elektor designs to other units (e.g. existing equipment) cannot normally be answered, owing to a lack of practical experience with those other units. An answer can only be based on a comparison of our design specifications with those of the other equipment.
3. Questions about suppliers for components are usually answered on the basis of advertisements, and readers can usually check these themselves.
4. As far as possible, answers will be on standard reply forms.

We trust that our readers will understand the reasons for these restrictions. On the one hand we feel that all technical queries should be answered as quickly and completely as possible; on the other hand this must not lead to overloading of our technical staff as this could lead to blown fuses and reduced quality in future issues.

NEW NICKEL CADMIUM

CELLS	1.2v
D Cell (U2 size) 4A/H	£2.20
C Cell (U11 size) 2A/H	£1.50
RR Cell 1.2A/H†	£1.10
R/C Cell 0.7A/H	£1.00
A.A. Cell 0.5A/H	£0.90

All above cells are vented - i.e. suitable for fast charging

BUTTON CELLS

1.2v	
200mA/H 40p	780mA/H 55p
500mA/H 70p	900mA/H £1.05
1.75A/H £1.50	

Ribbon cable 8 way 25p/metre
20 way 60p/metre

HIGH PERFORMANCE POWER SUPPLY KIT

Zero - 30v 5mA - 1.5A
O/P regulated 1mΩ (at board O/P)
Noise/ripple 1mV - very sharp current limit - generally idiot proof.
Kit of parts F/G PCB tuned controls, wire, all components £11.00
Schools/Colleges £10.00
P & P 85p

Vernitron 10m7 Ceramic Filters 50p
455k Ceramic Filters 50p
Stereo Cassette Deck Top Loading £90p
Mono Cassette Amp./OSC board with Circuit £1.50
LM107 Op. Amp. sim. 741/307 (compensated 301 but no offset null) 20p
Humidity Switch (Adjustable) 60p
Air operated Switch ½ PSI £1.00 (30p)
2 Pole Mains Latching Relay £1.00 (30p)
Cradle Filter 6001 24v Varley type with 800V 10 Turn Presets - ideal FM/TV Tuners 30p £20/100 £100/1000
10 Turn Trimpots - 10R, 20R, 100R, 200R, 500R, 2k, 5k, 20k, 22k, 50k, 40p
10000pF 10kV Caps (qty available) 25p
Sprague 30A RFI Filter £5.00 (80p)

SUB MIN BUTTON MICROSWITCH 337-829 50p
FUTABA FLUORESCENT DISPLAY £1.50
4 digit 9-CT 01-3L £1.50
SPIRAP 30m ROLL £1

Heatshrink Sleeving Assorted 1m lengths £1.50 (25p)
250 mixed Resistors £1 (20p)
3½ digit LCD Display £4 (25p)
4 digit LCD Display £4 (25p)
Mono Cassette R/P Head £1 (25p)
Cassette Erase Head 60p (12p)

Rubber 13A Mains plug 65p (30p)
Rubber 13A trailing Slt. 65p (30p)
Regulators 78/79 series 5v, 12v, 15v, 24v 80p (12p)

Convergence Pots - 20 assorted £1 (25p)
LM324 Quad 741 14 pin DIL 70p (12p)
1458 Dual 741 8 pin DIL 60p (12p)

ERO 150n 10% AX 250v £3.50/100
ERO 100n 10% AX 100v £4/100
ERO 10n 10% AX 100v £2.50/100
2u2 C280 £9/100, £70/1000
1µ5 MULLARD AX. £7/100

MIN. ORDER £2/MIN. P&P 35p OFFICIAL ORDERS WELCOME
UNIVERSITIES - COLLEGES - SCHOOLS - GOVT. DEPARTMENTS
WILL REFUND EXCESS P&P (P&P SHOWN IN BRACKETS)

ADD 15% VAT TO TOTAL

KEYTRONICS

332 LEY STREET, ILFORD, ESSEX
Shop open Mon. - Sat. 9.30 a.m. - 2 p.m.
TELEPHONE 553 1863

DIODES

IN914 Equiv. IN4148	£1.50/100
1S34 PD Ge	£1/100
IS44	£1.25/100
IN4003 1A 300v	£3/100

BRIDGE RECS.

3A 200v	30p
1.5A 200v	20p
2.5A 100v	30p
SCR 600v 10A	90p
TRIAC 800v 8A	85p
TRIAC 400v 4A	60p
SCR 100A 600v	£3
BC1078 ITT	£8/100
BC215	£8/100
BSY84	£10/100
BF Y64	£9/100
PBC108 (TO92)	£4/100

1A TO5 TRANSISTORS

Sim. BF Y64 but 25v	£10/100
---------------------	---------

TESTED 2N3055 ex. eqpt.	20p
SCR C106F no Tabs 4A 100v	30p
	£20/100
2N5777 (Photo Darlington)	50p
BC238, BC239	£30/100
PBC PINS fit 0.1" Veroboard	£5/100
	50p/100
	£3/1000

WW RESISTORS

0.111% 10w	25p
0.311% h/sink 25w	35p
T1591 UNIJ.	30p
2N3856	60p
OC29	80p
MELT12 Photo Darlington (base o/c)	50p
Photo Diode	25p
KSP1052 Esquiv. 2N3440	50p
Light Dependent Resistor	50p
TO18 case	60p
LDR RPY 58	50p

Zeners 400mW	£4.50/100
2v7, 3v3, 3v6, 4v7, 5v6, 6v2,	£35/1000
Zeners 1w/1w3	£7/100
5v6, 7v, 8v2, 12v, 15v, 18v, 27v, 33v, 51v	

TO3 Mounting Kits	£2.50/100
TO220 Mounting Kits	£2/100

TRANSFORMERS

12v 10A	£6 (90p)
12v 4A	£2.25 (65p)
22v, 8v, 6v, 50vA	£2.50 (80p)
20v 1A	£2.25 (50p)

30.0-30v 6A Toroid	£12 (1.25)
3v 3A	£1.60 (65p)

FOLD FLAT INSTRUMENT HANDLES

	25p, £15/100
Stereo Cassette Head	£5 (12p)
Mono Cassette Mic.	£1.50 (20p)

6v Cassette Motor	£1 (25p)
-------------------	----------

CAPACITORS

Sprague 26,000µ 30v	£1.50 (35p)
4700µ 25v	60p (20p)
4700µ 35v	70p (20p)
4700µ 63v	80p (25p)
Paper 1µ 700v - ideal electronic ignition	70p (25p)

CLASSIFIED

CONDITIONS OF ACCEPTANCE OF CLASSIFIED ADVERTISEMENTS

1. Advertisements are accepted subject to the conditions appearing on our current rate card and on the express understanding that the Advertiser warrants that the advertisement does not contravene any Act of Parliament nor is it an infringement of the British Code of Advertising Practice.

2. The Publishers reserve the right to refuse or withdraw any advertisement.

3. Although every care is taken, the Publishers shall not be liable for clerical or printer's errors or their consequences.

4. The Advertiser's full name and address must accompany each advertisement submitted.

The prepaid rate for Classified Advertisements is 13 pence per word (minimum 12 words). Semi-display setting £4.40 per single column centimetre (minimum 2.5 cms.). All cheques, postal orders, etc. to be made payable to Elektor Publishers Ltd, Treasury notes should always be sent by registered post. Advertisements, together with remittance, should be sent to the Classified Advertisement Manager, Elektor Publishers Ltd., 10 Longport, Canterbury, Kent CT1 1PE.

FREE 1980 AMTRON Catalogue with new range of kits and equipment cabinets. Send S.A.E. to
AMTRON UK LTD.,
7 HUGHENDEN ROAD,
HASTINGS, SUSSEX TN34 3TG.
Telephone Hastings 436004

CLEARANCE PARCELS:
TRANSISTORS, RESISTORS,
BOARDS, HARDWARE, 101 lbs. -
only **£5.80!**
1000 RESISTORS **£4.25**
500 CAPACITORS **£3.75**
BC108, BC171, BC204, BC230,
2N5061, CV7497 TRANSISTORS
10 70p 100 **£5.80**
2N3055, 10 for **£3.50**, S.A.E. for
lists: W.V.E. (4),
15 HIGH STREET, LYDNEY,
GLOUCESTER.

Do you need electronic components - tools-test meters etc. YES! -
Then send 30p per our catalogue to:
LIGHTNING ELECTRONIC COMPONENTS, Dept ELK, FREEPOST, TAMWORTH, STAFFS. B77 1BR.

ELEKTOR μ P TV GAMES COMPUTER Program Exchange!
Please send me your typewritten program lists (plus a self-addressed envelope, A4, 2 International Reply Coupons, and a handling charge of £3) and I will collect, print (offset), and return to you copies of all the best games sent to me. In this way we can cheaply have many more games to play with. Please write to:
MR. P.J. WALKER,
AN DER SCHANZ 2 (17/3),
5000 COLOGNE 60, W. GERMANY.

PRINTED CIRCUITS. Make your own simply, cheaply and quickly!
Golden Fotolak Light Sensitive Lacquer - now greatly improved and very much faster. Aerosol cans with full instructions - £2.25. Developer - 35p. Ferric Chloride - 55p. Clear Acetate sheet for master 14p. Copper-clad Fibre-glass Board approx. 1mm thick - £1.75 sq. ft. Post & Packing 60p.
WHITE HOUSE ELECTRONICS,
P.O. BOX 19,
PENZANCE, CORNWALL.

50 MIXED TRANSISTORS 95p
extra thin copper plated fibre board
72 square inches 90p: Lists 15p
SOLE ELECTRONICS (ELKR),
37 STANLEY STREET,
ORMSKIRK, LANCs. L39 2DH.

TUNBRIDGE WELLS COMPONENTS
at **BALLARD'S, 108 CAMDEN RD.,**
Tel. 31803. No lists, SAE for enquiries

APPOINTMENTS

REQUIRED:
WORKSHOP ENGINEER familiar with repairing Micro Processor Controlled System. Experience welcome, but not necessary.

Please write to:
VIDEO GAMES SALES,
24 LANGROD ROAD,
LONDON SW17.

ADVERTISERS INDEX

Breadbord '80	UK 15
S. & R. Brewster	UK 10
British National Radio & Electronics School	UK 17
Codespeed Electronics	UK 08
Coiltronic	UK 21
Doram Electronics	UK 07
Electrovalue	UK 20
Keytronics	UK 14
Lascar Electronics	UK 12
Maclin-Zand Electronics	UK 11
Maplin	UK 02
Marshall's	UK 19
Microcircuits	UK 09
G.F. Milward	UK 19
Monolith Electronics	UK 17
Orbit Electronics	UK 19
Phonosonics	UK 17
T. Powell	UK 26
Ramar	UK 21
Safgan Electronics	UK 19
Suretron Systems	UK 21
Technomatic	UK 25
TK Electronics	UK 08

PLEASE NOTE :

FROM 1st NOVEMBER 1980 THE RATE FOR CLASSIFIED ADVERTISEMENTS (PREPAID) WILL BE INCREASED TO 20 PENNY PER WORD (MINIMUM 12 WORDS).
SEMI-DISPLAY SETTING WILL BE INCREASED TO £5.50 PER SINGLE COLUMN CENTIMETRE (MINIMUM 2.5 CMS).